

7 Canali per cablaggio. Wire ducts.

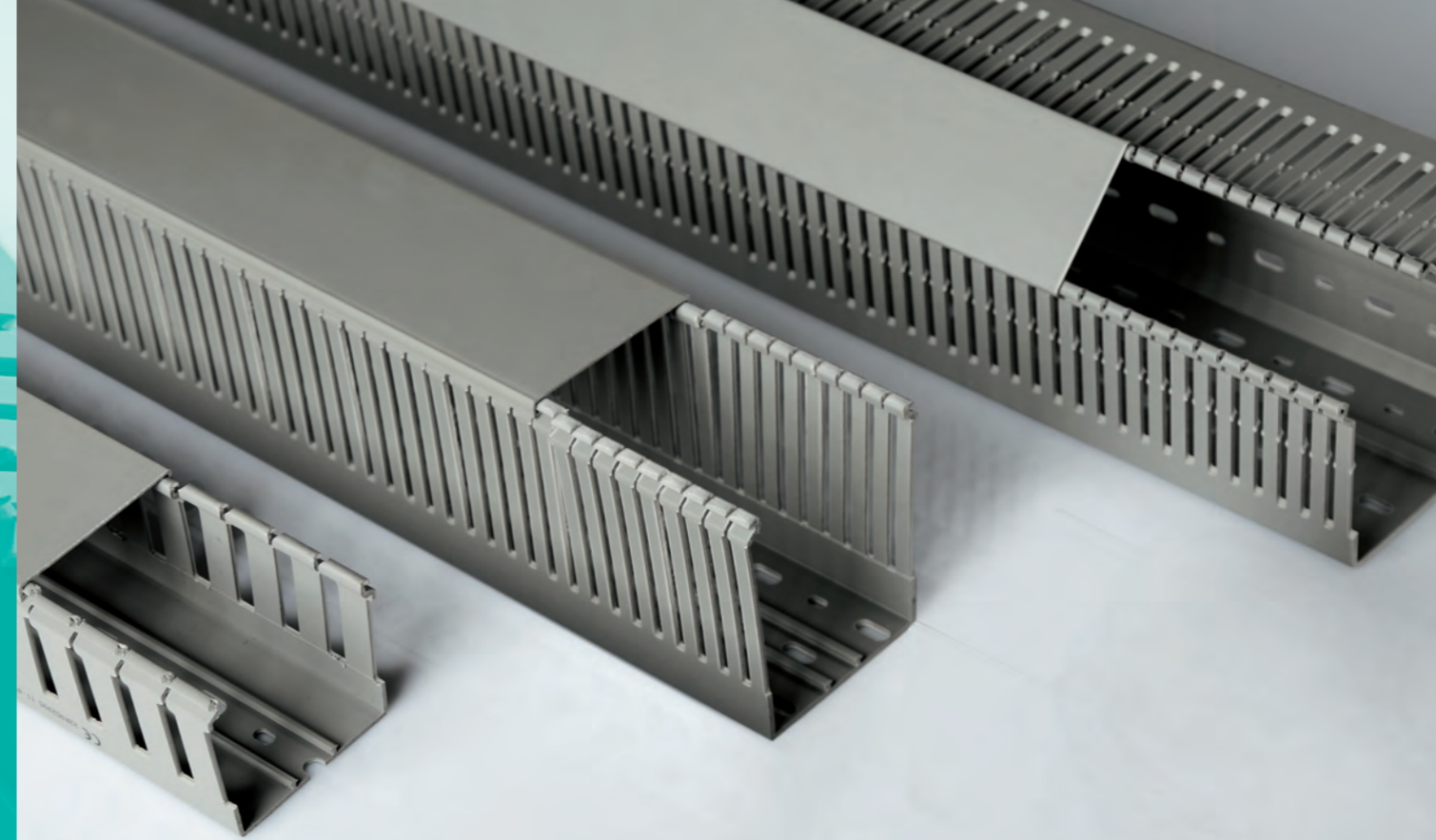

Canali per cablaggio Wire ducts



E

pag. 7.1.1



**Accessori.
Accessories.**
pag. 7.5.1



E/4

pag. 7.1.4

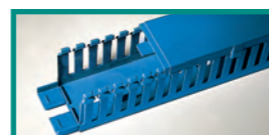

PA

pag. 7.7.1



EDGE

pag. 7.2.1



NXA

pag. 7.8.1



**Spirale, canale flessibile, guaine.
Spiral, flexible duct, sheaths.**
pag. 7.4.1

Canali per cablaggio con feritoie e lamelle larghe per un inserimento facilitato dei cavi. Senza piombo.
Wiring ducts with large fingers and larger slots for easy insertion of larger wires and cables. Lead free.



E

pagina / page 7.1.2

Progettato per applicazioni con morsetti e componenti DIN con un alto numero di ingressi nella canalina. Senza piombo.
Designed for terminal block and Din component applications with higher number of entries into the duct. Lead free.



E/4

pagina / page 7.1.4

Canale angolare componibile per cablaggio. Senza piombo.
Modular wiring duct for mounting in the corners of the enclosure. Lead free.



EDGE

pagina / page 7.2.1

**Dati tecnici.
Technical data.**



pagina / page 7.3.1

**Spirale, canale flessibile, guaine.
Spiral, flexible duct, sheaths.**



pagina / page 7.4.1

**Accessori.
Accessories.**



pagina / page 7.5.1



Fermacavi incorporato. Feritoie con doppio restringimento disponibile su alcuni formati. **Ingresso arrotondato per i cavi.** Permette una rapida installazione dei cavi. **Built-in wire retainer.** Double restricted slots on some sizes. **Smooth wire entry.** Allows for quick insertion of wires.

Guide sul fondo incorporate. Permette una veloce installazione degli accessori senza bisogno di ulteriori fissaggi, risparmiando tempo e denaro. **Built-in rail.** Allows quick installation of accessories without the need for additional hardware; time and money saver.

Lamelle arrotondate
Non graffiano l'installatore e non danneggiano i cavi
Smooth fingers
Will not hurt the installer or damage wires or cables.

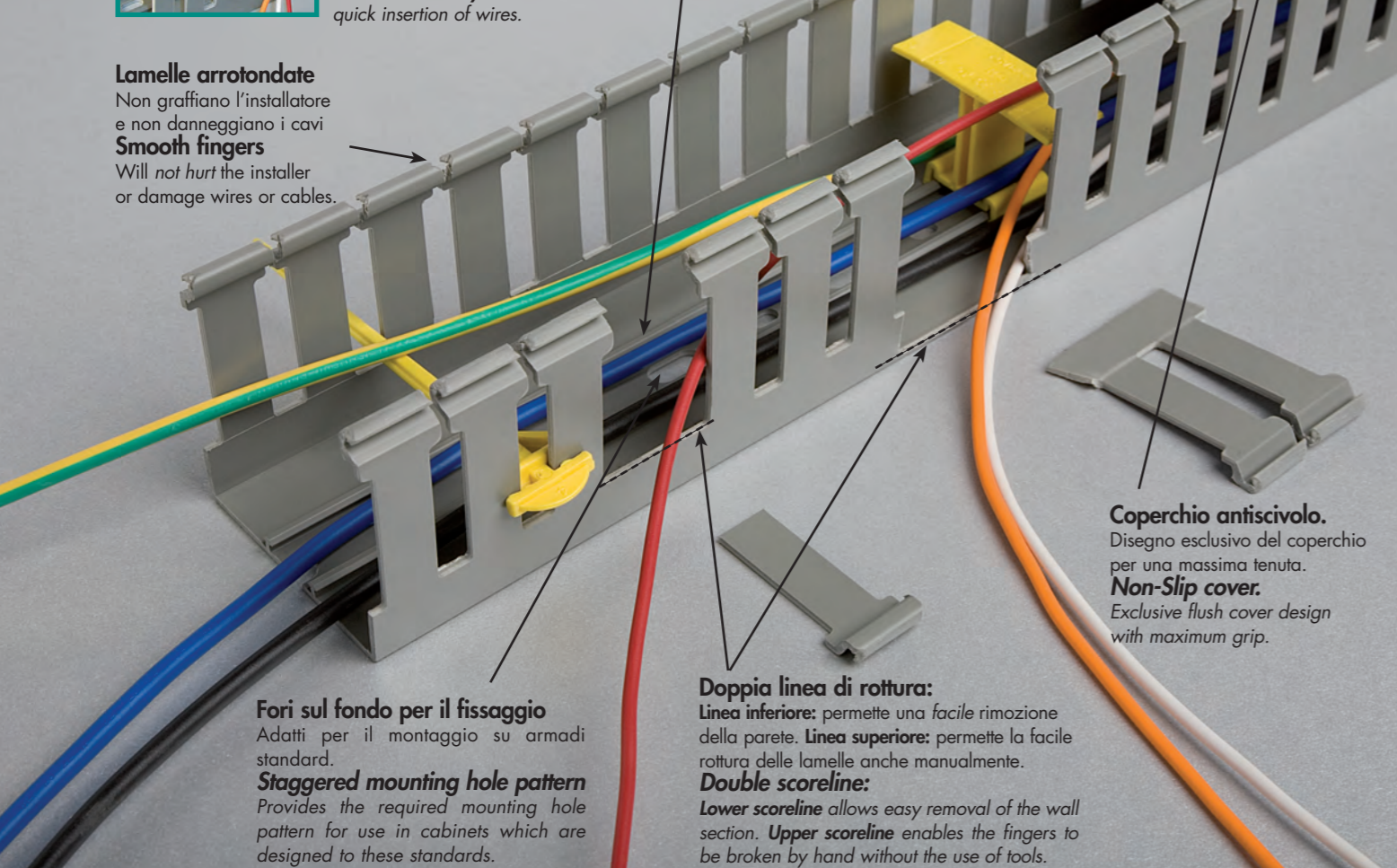

Fori sul fondo per il fissaggio
Adatti per il montaggio su armadi standard.
Staggered mounting hole pattern
Provides the required mounting hole pattern for use in cabinets which are designed to these standards.

Doppia linea di rottura:
Linea inferiore: permette la facile rimozione della parete. **Linea superiore:** permette la facile rottura delle lamelle anche manualmente.
Double scoreline:
Lower scoreline allows easy removal of the wall section. **Upper scoreline** enables the fingers to be broken by hand without the use of tools.

Coperchio antiscivolo.
Disegno esclusivo del coperchio per una massima tenuta.
Non-Slip cover.
Exclusive flush cover design with maximum grip.



Canali per cablaggio con feritoie e lamelle larghe per un inserimento facilitato dei cavi.
Materiale: PVC Rigido Autoestinguente Classe 1 (UL94-VO).
Lunghezza: 2 metri
Wiring ducts with large fingers and large slots for easy insertion of larger wires and cables.
Self-extinguishing rigid PVC Class 1 (UL94-VO).
Length: 2 meters



Codifica per l'ordine dei canali
Functional part numbering system

E20 *

■ Tipo
■ Colore
■ Type
■ Colour

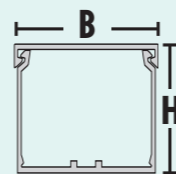

COLORI COLOURS
■ G = Grigio / Grey Type 7030
■ B* = Bianco / White
■ BL* = Blu / Blue Type 5012
■ N* = Nero / Black

* Da indicare se diverso da Grigio Type 7030.
* To indicate only if different from Grey Type 7030.

- I canali vengono forniti completi di coperchio.
- All wiring ducts come complete with cover.

Il marchio CaZn® e CZ contraddistinguono i canali per quadri elettrici prodotti con materie prime conformi alla Direttiva 2002/95/CE del Parlamento Europeo e del Consiglio del 27 gennaio 2003 sulla restrizione dell'uso di determinate sostanze pericolose nelle apparecchiature elettriche ed elettroniche. I materiali utilizzati non contengono come additivi composti: piombo, cromo esavalente, cadmio, mercurio, bifenilopolibromurati (PBB), eteri di difenili polibromurati (PBDE).
The RoHS Directive stands for "the restriction of the use of certain hazardous substances in electrical and electronic equipment". This Directive bans the use on the EU market of new electrical and electronic equipment containing more than agreed levels of lead, cadmium, mercury, hexavalent chromium, polybrominated biphenyl (PBB) and polybrominated diphenyl ether (PBDE) and it's in force since July 1, 2006.

*fornibile a richiesta e per quantità da concordare.
*on request and for quantities to be agreed.



Canali per cablaggio con feritoie da 8 mm.
Wire ducts with 8 mm. slots.



Coperchio disegnato per garantire la massima tenuta.
Flush cover design with maximum grip.



Progettato per l'utilizzo di diversi accessori.
Designed for use with several accessories.

Guide	Sezione fondo	Tipo	Dimensioni BxH mm	Colore	EAN	Imballo m	S.G. mm ²	Lung. barre m	Cartone peso Kg
Rails	Section of the bottom	Part number	Duct Size BxH mm	Colour	EAN Code	Standard Carton m	G.S. mm ²	Length m	Carton Weight Kg
	□	CZ E20	15x17	■	020111	120	170	2	11,3
	□	CZ E22	15x30	■	020128	96	320	2	14,1
	□	CZ E16	25x30	■	020074	80	550	2	16,0
	□	CZ E23	40x30	■	020135	48	920	2	13,5
	□	CZ E24	60x30	■	020142	32	1400	2	14,4
	□	CZ E25	15x40	■	020159	72	450	2	14,8
	□	CZ E13	25x40	■	020043	60	760	2	15,8
	□	CZ E8	40x40	■	020357	40	1310	2	14,2
	□	CZ E4	60x40	■	020289	24	1960	2	11,4
▲	□	CZ E4 CG	60x40	■	021071	24	1960	2	11,4
	□	CZ E26	80x40	■	020166	24	2655	2	14,3
▲	□	CZ E26 CG	80x40	■	021064	24	2655	2	14,3
▲	□	CZ E27	100x40	■	020173	16	3375	2	12,3
▲	□	CZ E28	120x40	■	020180	20	4070	2	18,2
	□	CZ E7	25x60	■	020340	40	1200	2	15,0
	□	CZ E5	40x60	■	020326	36	1960	2	17,8
▲	□	CZ E5 CG	40x60	■	021088	36	1960	2	17,8
	□	CZ E9	60x60	■	020364	24	3080	2	15,5
▲	□	CZ E9 CG	60x60	■	021101	24	3080	2	15,5
	□	CZ E6	80x60	■	020333	24	4175	2	19,2
▲	□	CZ E6 CG	80x60	■	021095	24	4175	2	19,2
	□	CZ E17	100x60	■	020081	20	5295	2	18,7
▲	□	CZ E17 CG	100x60	■	021040	20	5295	2	18,7
▲	□	CZ E10	120x60	■	020012	16	6390	2	17,5
▲	□	CZ E30	150x60	■	020197	12	8070	2	17,3
▲	□	CZ E31	200x60	■	020203	8	10820	2	14,6
	□	CZ E14	25x80	■	020050	32	1540	2	15,6
	□	CZ E15	40x80	■	020067	24	2680	2	14,7
▲	□	CZ E15 CG	40x80	■	021033	24	2680	2	14,7
	□	CZ E11	60x80	■	020029	24	4200	2	18,5
▲	□	CZ E11 CG	60x80	■	021019	24	4200	2	18,5
	□	CZ E12	80x80	■	020036	24	5695	2	21,7
▲	□	CZ E12 CG	80x80	■	021026	24	5695	2	21,7
	□	CZ E19	100x80	■	020104	16	7215	2	18,1
▲	□	CZ E19 CG	100x80	■	021057	16	7215	2	18,1
	□	CZ E32	120x80	■	020210	16	8710	2	20,5
▲	□	CZ E33	150x80	■	020227	12	10770	2	18,9
▲	□	CZ E48	200x80	■	020319	8	14470	2	16,6
	□	CZ E34	25x100	■	020371	24	2310	2	13,8
	□	CZ E35	40x100	■	020234	16	3350	2	14,1
	□	CZ E18	60x100	■	020098	16	5320	2	16,9
▲	□	CZ E36	80x100	■	020241	16	7125	2	19,8
▲	□	CZ E37	100x100	■	020258	16	9135	2	21,5
▲	□	CZ E38	120x100	■	020265	8	10820	2	12,6
▲	□	CZ E39	150x100	■	020272	8	13670	2	15,1
▲	□	CZ E40 *	200x100	■	020296	8	18370	2	18,2
	□	CZ E43	100x150	■	020302	8	13695	2	14,6

Accessori Accessories Selection			
Traversini Cross-Arms		Separatori Separators	
PTR	TR4		
PTR	TR6		
PTR	TR4		
PTR	TR6		
PTR	TR6	FCV12040	S1-S3
PTR	TR8		
PTR	TR8	FCV12040	S1-S3
PTR	TR10	FCV12040	S1-S3
PTR	TR10	FCV12040	S3
PTR	TR4		
PTR	TR4	FCV12060	S2
PTR	TR6		
PTR	TR6	FCV12060	S2
PTR	TR8		
PTR	TR8	FCV12060	S2
PTR	TR10		
PTR	TR10	FCV12060	S2
PTR	TR10	FCV12060	S2
		FCV12060	S2
PTR	TR4		
PTR	TR4		S4
PTR	TR6		
PTR	TR6		S4
PTR	TR8		
PTR	TR8		S4
PTR	TR10		
PTR	TR10		S4
PTR	TR10		S4
			S4
			S4
PTR	TR4		
PTR	TR6		
PTR	TR8		S5
PTR	TR10		S5
			S5
			S5
PTR	TR10		

■ Canali con feritoie da 4 mm. Wire ducts with 4 mm slots.

▲ Canali con guide sul fondo. Wire ducts with rails on the bottom.

● Canali disponibili a richiesta e per quantità da concordare. Wire Ducts available on request and for quantities to be agreed.

* Non certificato UL. No UL certification.



Fermacavi incorporato. Feritoie con doppio restringimento disponibile su alcuni formati.
Ingresso arrotondato per i cavi. Permette una rapida installazione dei cavi.
Built-in wire retainer. Double restricted slots on some sizes. **Smooth wire entry.** Allows for quick insertion of wires.

Coperchio antiscivolo. Disegno esclusivo del coperchio per una massima tenuta.
Non-Slip cover. Exclusive flush cover design with maximum grip.

Lamelle arrotondate. Non graffiano l'installatore e non danneggiano i cavi.
Smooth fingers. Will not hurt the installer or damage wires or cables.

Guide sul fondo incorporate. Permette una veloce installazione degli accessori senza bisogno di ulteriori fissaggi, risparmiando tempo e denaro.
Built-in rail. Allows quick installation of accessories without the need for additional hardware; time and money saver.

Doppia linea di rottura: Linea inferiore: permette una facile rimozione della parete. **Linea superiore:** permette la facile rottura delle lamelle anche manualmente.
Double scoreline: Lower scoreline allows easy removal of the wall section. **Upper scoreline** enables the fingers to be broken by hand without the use of tools.

Fori sul fondo per il fissaggio
Adatti per il montaggio su armadi standard.
Staggered mounting hole pattern
Provides the required mounting hole pattern for use in cabinets which are designed to these standards.

E/4

Progettato per applicazioni con morsetti e componenti DIN con un alto numero di ingressi nella canalina. Materiale: PVC Rigido Autoestinguente Classe 1 (UL94-VO). Lunghezza: 2 metri.
Designed for terminal block and Din component applications with higher number of entries into the duct. Self-extinguishing rigid PVC Class 1 (UL94-VO). Length: 2 meters



Codifica per l'ordine dei canali
Functional part numbering system

E16 4 *
 Tipo Type Colore Colour

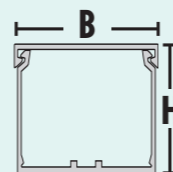

COLORI COLOURS

- G = Grigio / Grey Type 7030
- B* = Bianco / White
- BL* = Blu / Blue Type 5012
- N* = Nero / Black

*fornibile a richiesta e per quantità da concordare.
 *on request and for quantities to be agreed.

* Da indicare se diverso da Grigio Type 7030.
 * To indicate only if different from Grey Type 7030.

• I canali vengono forniti completi di coperchio.
 • All wiring ducts come complete with cover.

Il marchio CaZn® e CZ contraddistinguono i canali per quadri elettrici prodotti con materie prime conformi alla Direttiva 2002/95/CE del Parlamento Europeo e del Consiglio del 27 gennaio 2003 sulla restrizione dell'uso di determinate sostanze pericolose nelle apparecchiature elettriche ed elettroniche. I materiali utilizzati non contengono come additivi composti: piombo, cromo esavalente, cadmio, mercurio, bifenilipolibromurati (PBB), eteri di difenilipolibromurati (PBDE).
 The RoHS Directive stands for "the restriction of the use of certain hazardous substances in electrical and electronic equipment". This Directive bans the use on the EU market of new electrical and electronic equipment containing more than agreed levels of lead, cadmium, mercury, hexavalent chromium, polybrominated biphenyl (PBB) and polybrominated diphenyl ether (PBDE) and it's in force since July 1, 2006.

E/4

CaZn® Family



Coperchio disegnato per garantire la massima tenuta. Flush cover design with maximum grip.



Progettato per l'utilizzo di diversi accessori. Designed for use with several accessories.

Canali per cablaggio con feritoie da 4 mm.
 Wire ducts with 4 mm slots.

Guide	Sezione fondo	Tipo	Dimensioni BxH mm	Colore	EAN	Imballo m	S.G. mm ²	Lung. barre m	Cartone peso Kg
Rails	Section of the bottom	Part number	Duct Size BxH mm	Colour	EAN Code	Standard Carton m	G.S. mm ²	Length m	Carton Weight Kg

		CZ E16 4	25x30		020579	80	550	2	15,9
		CZ E13 4	25x40		020548	60	760	2	15,6
		CZ E8 4	40x40		020661	40	1310	2	14,1
		CZ E4 4	60x40		020623	24	1960	2	11,5
▲●	□	CZ E4 4 CG	60x40		021576	24	1960	2	11,5
		CZ E26 4	80x40		020609	24	2655	2	14,6
▲●	□	CZ E26 4 CG	80x40		021569	24	2655	2	14,6
		CZ E7 4	25x60		020654	40	1200	2	15,1
		CZ E5 4	40x60		020630	36	1960	2	17,7
▲●	□	CZ E5 4 CG	40x60		021583	36	1960	2	17,7
		CZ E9 4	60x60		020678	24	3080	2	15,5
▲●	□	CZ E9 4 CG	60x60		021606	24	3080	2	15,5
		CZ E6 4	80x60		020647	24	4175	2	19,0
▲●	□	CZ E6 4 CG	80x60		021590	24	4175	2	19,0
		CZ E17 4	100x60		020586	20	5295	2	18,7
▲●	□	CZ E17 4 CG	100x60		021545	20	5295	2	18,7
▲	□	CZ E10 4	120x60		020517	16	6390	2	17,3
		CZ E14 4	25x80		020555	32	1540	2	15,6
		CZ E15 4	40x80		020562	24	2680	2	14,4
▲●	□	CZ E15 4 CG	40x80		021538	24	2680	2	14,4
		CZ E11 4	60x80		020524	24	4200	2	18,4
▲●	□	CZ E11 4 CG	60x80		021514	24	4200	2	18,4
		CZ E12 4	80x80		020531	24	5695	2	21,6
▲●	□	CZ E12 4 CG	80x80		021521	24	5695	2	21,6
		CZ E19 4	100x80		020593	16	7215	2	18,1
▲●	□	CZ E19 4 CG	100x80		021552	16	7215	2	18,1
▲	□	CZ E32 4	120x80		020616	16	8710	2	20,9
		CZ E34 4	25x100		020685	24	2310	2	13,8
		CZ E35 4	40x100		020692	16	3350	2	14,1
		CZ E18 4	60x100		020708	16	5320	2	16,9
▲	□	CZ E36 4	80x100		020715	16	7125	2	19,8
▲	□	CZ E37 4	100x100		020722	16	9135	2	21,5

Accessori Accessories Selection

Traversini Cross-Arms Separatori Separators

PTR	TR4		
PTR	TR6		
PTR	TR6	FCV12040	S1-S3
PTR	TR8		
PTR	TR8	FCV12040	S1-S3
PTR	TR4		
PTR	TR4	FCV12060	S2
PTR	TR6		
PTR	TR6	FCV12060	S2
PTR	TR8	FCV12060	S2
PTR	TR10		
PTR	TR10	FCV12060	S2
PTR	TR10	FCV12060	S2
PTR	TR4		
PTR	TR4		S4
PTR	TR6		
PTR	TR6		S4
PTR	TR8		
PTR	TR8		S4
PTR	TR10		
PTR	TR10		S4
PTR	TR4		
PTR	TR6		
PTR	TR8		S5
PTR	TR10		S5

▲ Canali con guide sul fondo. Wire ducts with rails on the bottom. ● Canali disponibili a richiesta e per quantità da concordare. Wire Ducts available on request and for quantities to be agreed.

EDGE

CaZn®
Family

ED110: Canali angolari per quadri elettrici con feritoie da 4 mm.
ED110: Corner wire duct for electrical panels with 4 mm slots.



Progettato per l'utilizzo di diversi accessori.
Designed for use with several accessories.

Tipo	Referenze	Dimensioni mm	Colore	EAN	Imballo m	S.G. mm ²	Lung. barre m	Cartone peso Kg
Part number	Reference	Duct Size mm	Colour	EAN Code	Standard Carton m	G.S. mm ²	Length m	Carton Weight Kg
CZ ED110	K40	90x90	■	022832	8	9000	2	12,5
	K60	110x110	■	022825	8	11050	2	13,1

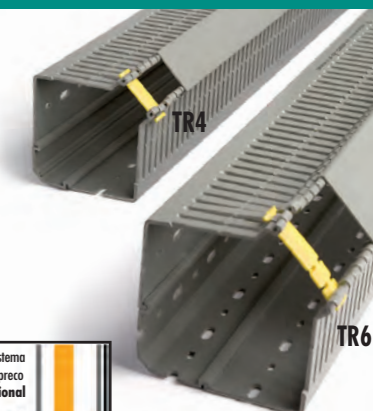

I vantaggi del sistema.

Il canale angolare Edge riempie gli spazi vuoti che si creano negli angoli del quadro utilizzando canali rettangolari tradizionali e consente di effettuare giunzioni ortogonali che determinano un aumento sensibile della sezione utile interna per il passaggio dei cavi.

Caratteristiche del canale.

Disponibile con aperture 40 e 60 mm (90x90-110x110) e sez. utili di 9000 e 11050 mm². Variando solo il fondo angolato e mantenendo la stessa parete si avrà un risparmio sensibile dei costi del canale e del magazzino, oltre ad un aumento di volumi di utilizzo per lo stipaggio dei cavi all'interno del quadro elettrico.



Advantages of the system.

The Edge wire duct is designed to exploit the corner of the enclosure where the space is normally not utilized. This system allows wires and cables to be routed professionally to the lateral panels.

Features of the EDGE duct.

Available with cover opening of 40 and 60 mm (90x90-110x110) and useful sections of 9000 and 11050 mm². Just changing the "L" shaped bottom piece and keeping the same side wall, you will get a big saving on the ducts and stocking costs, beside getting an increase in wire fill capacity inside the electrical panel.

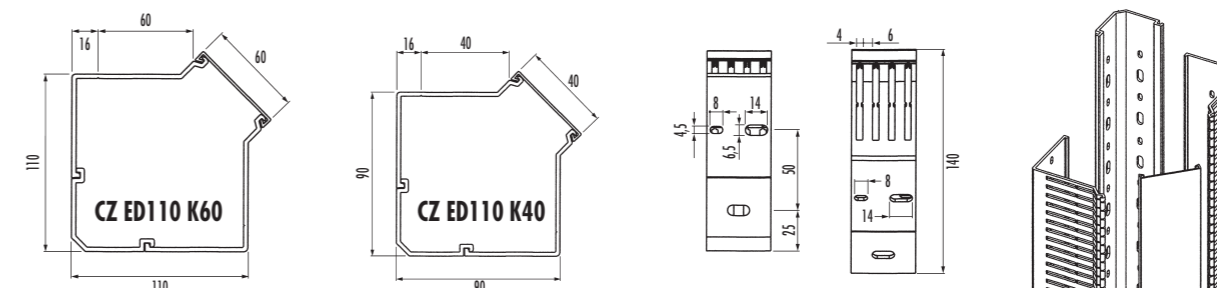

EDGE

Brevetto / Patented:
N° 00246688
MI99U000250
23/04/1999



Canale angolare componibile per cablaggio.

Materiale: PVC Rigido Autoestinguente Classe 1 (UL94-VO). Lunghezza: 2 metri

Modular corner wire duct for cabling.

Self-extinguishing rigid PVC Class 1 (UL94-VO). Length: 2 meters



Codifica per l'ordine dei canali
Functional part numbering system

ED110	Kxx	*
Tipo Type	Referenza Reference	Colore Colour

* Da indicare se diverso da Grigio Type 7030.

* To indicate only if different from Grey Type 7030.

Il marchio CaZn® e Cz contraddistingue i canali per quadri elettrici prodotti con materie prime conformi alla Direttiva 2002/95/CE del Parlamento Europeo e del Consiglio del 27 gennaio 2003 sulla restrizione dell'uso di determinate sostanze pericolose nelle apparecchiature elettriche ed elettroniche. I materiali utilizzati non contengono come additivi composti: piombo, cromo esavalente, cadmio, mercurio, bifenilopolibromurati (PBB), eteri di difenili polibromurati (PBDE).

The RoHS Directive stands for "the restriction of the use of certain hazardous substances in electrical and electronic equipment". This Directive bans the use on the EU market of new electrical and electronic equipment containing more than agreed levels of lead, cadmium, mercury, hexavalent chromium, polybrominated biphenyl (PBB) and polybrominated diphenyl ether (PBDE) and it's in force since July 1, 2006.

COLORI COLOURS

■	G = Grigio / Grey Type 7030
■	B* = Bianco / White
■	BL* = Blu / Blue Type 5012
■	N* = Nero / Black

*fornibile a richiesta e per quantità da concordare.
*on request and for quantities to be agreed.

Installazione.

Innestando le due pareti fessurate con cave da 4 mm sul fondo angolato si sfruttano le possibilità di utilizzare i pannelli di fondo e laterali per il posizionamento di strumenti e morsetti. Si evitano così applicazioni strane che, per ottenere lo stesso scopo, richiedono il fissaggio del canale tradizionale su staffe angolate: una soluzione che limita però lo spazio di contenenza dei cavi.

Installation.

Connecting the two slotted walls, 4 mm slots, you have the possibility to use the bottom and side panels for the fixing of instruments and terminals. You can avoid strange applications that, to get the same result, need the fixing of the traditional duct on corner clamps, a solution that restricts the space available for cables.

(fig. A)



Fissare il profilo angolare tra i due pannelli e/o traverse del quadro, con 2-4 rivetti (RIV1) o viti per metro (vedi fig. A). Incastrare sotto l'angolare e nelle apposite scanalature le pareti asolate. Fissare al pannello con 2-4 rivetti (RIV1) per metro. Innestare a scatto il coperchio. Per la tenuta cavi, utilizzare il traversino TR4- TR6 non in dotazione (vedere pag. 7.5.2).

Fix the corner profile between the panels, with 2-4 rivets (RIV1) or screw per meter (see fig. A). Set under the profile and in the suitable grooves the slotted walls. Fix the panel with 2-4 rivets (RIV1) per meter. Fix the cover by pressing. To hold back the wires, use the cross arm TR4-TR6 not supplied (see pag. 7.5.2).

7

CANALI PER CABLAGGIO / WIRE DUCTS

Dimensione canali. Duct dimensions.

Dimensioni Dimension (BxH)	A	B	C	D	E	F	F1	G	H
TIPO E - TYPE E									
15 x 17	15	17	15	4	6	7		5	12
15 x 30	15	30	15	4	6	12		9	12
25 x 30	25	30	25	8	12	12		9	20
40 x 30	40	30	40	8	12	12		9	20
60 x 30	60	30	60	8	12	12		9	20
15 x 40	15	40	15	4	6	17		12	12
25 x 40	25	40	25	8	12	17		12	20
40 x 40	40	40	40	8	12	17		12	20
60 x 40	60	40	60	8	12	17		12	20
80 x 40	80	40	80	8	12	17		12	20
100 x 40	100	40	100	8	12	17		12	20
120 x 40	120	40	120	8	12	17		12	20
25 x 60	25	60	25	8	12	37		14	20
40 x 60	40	60	40	8	12	37		14	20
60 x 60	60	60	60	8	12	37		14	20
80 x 60	80	60	80	8	12	37		14	20
100 x 60	100	60	100	8	12	37		14	20
120 x 60	120	60	120	8	12	37		14	20
150 x 60	150	60	150	8	12	37		14	20
200 x 60	200	60	200	8	12	37		14	20
25 x 80	25	80	25	8	12		55	16	20
40 x 80	40	80	40	8	12		55	16	20
60 x 80	60	80	60	8	12		55	16	20
80 x 80	80	80	80	8	12		55	16	20
100 x 80	100	80	100	8	12		55	16	20
120 x 80	120	80	120	8	12		55	16	20
150 x 80	150	80	150	8	12		55	16	20
200 x 80	200	80	200	8	12		55	16	20
25 x 100	25	100	25	8	12		72	20	20
40 x 100	40	100	40	8	12		72	20	20
60 x 100	60	100	60	8	12		72	20	20
80 x 100	80	100	80	8	12		72	20	20
100 x 100	100	100	100	8	12		72	20	20
120 x 100	120	100	120	8	12		72	20	20
150 x 100	150	100	150	8	12		72	20	20
200 x 100	200	100	200	8	12		72	20	20
100 x 150	100	150	100	20	30		110	26	50

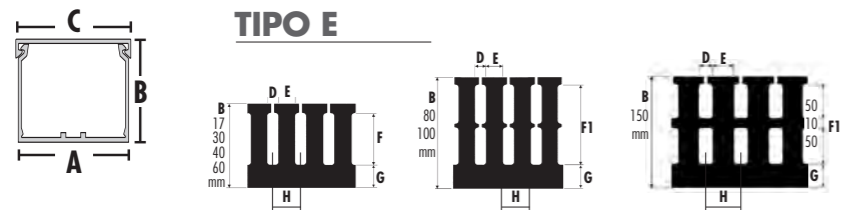

Disposizione fori sul fondo/Sizes and layout of holes on the bottom: Tipo E - E/4

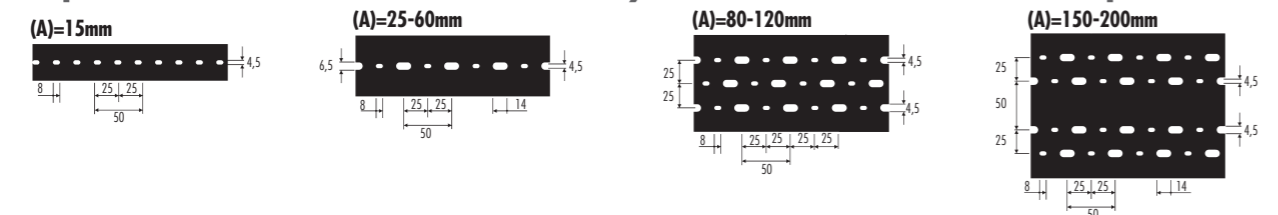

Contenimento cavi. Wire fill capacity chart.

Dimensioni BxH mm	S.G. mm ²	CAVI ELETTRICI											COMMUNICATION					
		8 AWG		10 AWG		12 AWG		14 AWG		16 AWG		18 AWG		22 AWG		24 AWG		
		.216 THHN	.153 THHN	.122 THHN	.158 MTW	.105 THHN	.139 MTW	.165 MTW	.096 TFFN	.125 MTW	.084 TFFN	.113 MTW	.065 MTW	.217 UTP/CM Cat5e	.250 STP/CM Cat6e	.422 UPT/CM		
15 x 17	170	3	5	10	6	14	8	6	16	10	21	12	36	3	2	1		
15 x 30	320	6	10	19	11	52	15	10	31	18	40	22	67	6	5	1		
25 x 30	550	10	16	33	20	89	25	18	53	31	69	37	116	10	8	2		
40 x 30	920	18	27	55	33	148	42	30	89	52	116	62	193	17	13	4		
60 x 30	1400	27	42	84	50	226	64	46	135	80	176	94	294	26	20	5		
15 x 40	450	9	13	27	16	72	21	15	43	26	57	30	95	8	6	2		
25 x 40	760	14	23	45	27	122	35	25	73	43	96	51	160	14	11	3		
40 x 40	1310	25	39	78	47	211	60	43	126	74	165	88	275	25	19	5		
60 x 40	1960	37	58	117	70	316	90	64	189	111	247	132	412	37	28	8		
80 x 40	2655	51	79	158	94	428	122	87	256	151	334	179	558	50	38	10		
100 x 40	3375	64	101	201	120	544	155	110	325	192	425	227	709	64	48	13		
120 x 40	4070	77	121	243	145	656	187	133	392	231	512	274	856	77	58	16		
25 x 60	1200	23	36	72	43	193	55	39	116	68	151	81	252	23	17	5		
40 x 60	1960	37	58	117	70	316	90	64	189	111	247	132	412	37	28	8		
60 x 60	3080	59	92	184	110	496	142	100	297	175	388	208	647	58	44	12		
80 x 60	4175	79	124	249	149	673	192	136	402	237	525	281	878	79	59	16		
100 x 60	5295	101	158	316	188	853	243	173	510	301	666	357	1113	100	75	21		
120 x 60	6390	122	190	381	227	1029	294	208	616	363	804	431	1343	121	91	25		
150 x 60	8070	154	240	482	287	1300	371	263	778	459	1016	544	1696	152	115	32		
200 x 60	10820	206	322	648	385	1743	497	353	1043	615	1362	729	2274	204	154	42		
25 x 80	1540	29	46	92	55	248	71	50	148	88	194	104	324	29	22	6		
40 x 80	2680	51	80	160	95	432	123	87	258	152	337	181	563	51	38	10		
60 x 80	4200	80	125	251	149	677	193	137	405	239	529	283	883	79	60	16		
80 x 80	5695	108	170	340	203	917	262	186	549	324	717	384	1197	107	81	22		
100 x 80	7215	137	215	431	257	1162	332	235	695	410	908	486	1517	136	103	28		
120 x 80	8710	166	260	520	310	1403	400	284	839	495	1096	587	1831	164	124	34		
150 x 80	10770	205	321	643	383	1735	495	351	1038	612	1356	726	2264	203	153	42		
200 x 80	14470	275	431	863	515	2331	665	472	1394	822	1821	975	3042	273	206	57		
25 x 100	2310	44	69	137	82	371	106	75	222	131	289	155	483	43	33	9		
40 x 100	3350	64	100	200	119	540	154	109	323	190	422	226	704	63	48	13		
60 x 100	5320	101	159	317	189	857	245	174	513	302	670	359	1118	100	76	21		
80 x 100	7125	136	212	425	253	1148	327	232	687	405	897	480	1498	134	101	28		
100 x 100	9135	174	272	545	325	1472	420	298	880	519	1150	616	1920	172	130	36		
120 x 100	10820	206	322	646	385	1743	497	353	1043	615	1362	729	2274	204	154	42		
150 x 100	13670	260	407	816	486	2202	628	446	1317	777	1721	921	2873	258	194	54		
200 x 100	18370	350	547	1096	654	2960	844	599	1770	1044	2312	1238	3861	346	261	72		
100 x 150	13695	261	408	817	487	2206	629	447	1320	778	1724	923	2879	258	195	54		

Dati tecnici. Technical data.

Guide sul fondo e separatori. Sizes and layout of rails for separators use.

Guide: Rails:

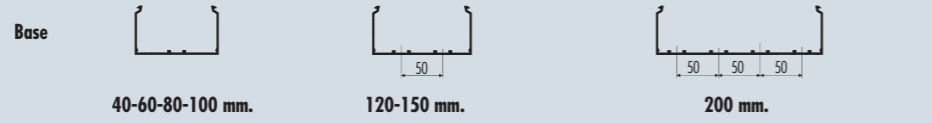

Dimensione e disposizione guide sul fondo per posizionamento separatori.
Il canale si fissa a parete con tasselli TS, 2/4 per metro per le misure piccole, 4/8 per metro per le misure più grandi.

Sizes and layout of rails on the bottom for separators use.

Trunking is fastened to the wall by TS nogs, 2/4 per meter for the smaller sizes, 4/8 per meter for the larger sizes.

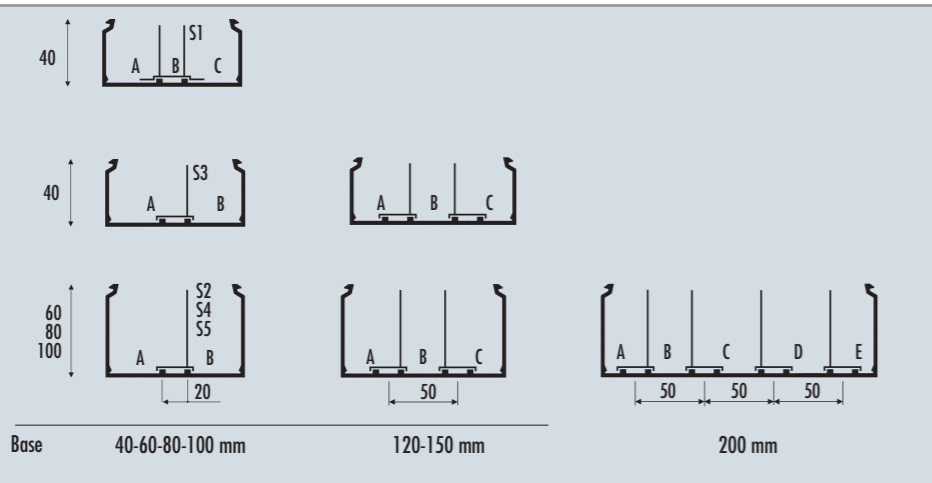

Utilizzo dei separatori S. Sezione degli scomparti in mm²

Use of the S separators. Compartments section in mm²

Dimensione canale Wiring duct sizes	N° scomparti N° compartments	Sezione / Section				
		A	B	C	D	E
mm.	S1	mm²	mm²	mm²		
60 x 40	3	680	425	680	-	-
80 x 40	3	1030	425	1030	-	-
100 x 40	3	1387	425	1387	-	-
	S2 / S3 / S4 / S5					
60 x 40	2	1223	737	-	-	-
80 x 40	2	1565	1090	-	-	-
100 x 40	2	1930	1445	-	-	-
120 x 40	3	1387	1295	1387	-	-
60 x 60	2	2060	1020	-	-	-
80 x 60	2	2607	1567	-	-	-
100 x 60	2	3167	2127	-	-	-
120 x 60	3	2170	2035	2170	-	-
150 x 60	3	3015	2035	3015	-	-
200 x 60	5	1750	2035	2640	2640	1750
60 x 80	2	2820	1380	-	-	-
80 x 80	2	3567	2127	-	-	-
100 x 80	2	4327	2887	-	-	-
120 x 80	3	2965	2775	2965	-	-
150 x 80	3	3995	2775	3995	-	-
200 x 80	5	2247	2775	3600	3600	2247
100 x 100	2	5487	3647	-	-	-
120 x 100	3	3705	3404	3705	-	-
150 x 100	3	5130	3404	5130	-	-
200 x 100	5	3065	3404	4416	4416	3065

Spirale - Canale flessibile. Spiral - Flexible duct.

CP

(Conformità RoHS)
(RoHS compliance)

Tipo Part number	Ø mm.	Cod. EAN	Imballo / Packing m.
Normale Trasparente / Transparent normal			
CP3	3	027141	400 (8x50)
CP6	6	027165	200 (8x25)
CP8	8	027172	100 (4x25)
CP10	10	027110	100 (4x25)
CP12	12	027127	100 (4x25)
CP14	14	027134	60 (3x20)
Autoestinguente Bianca V2 / Self-extinguishing white V2			
CPA3	3	027202	400 (8x50)
CPA6	6	027226	200 (8x25)
CPA10	10	027189	100 (4x25)
CPA12	12	027196	100 (4x25)
Normale Nera / Black normal			
CPN3	3	027257	400 (8x50)
CPN6	6	027264	200 (8x25)
CPN8	8	027271	100 (4x25)
CPN10	10	027233	100 (4x25)
CPN12	12	027240	100 (4x25)

Spirale.
Per la formazione rapida e ordinata dei cavi.
Materiale: Polietilene.

Spiral.
For quick and tidy forming of wire bundles.
Material: Polyethylene.

COLORI / COLOURS:

- Nero / Black
- Bianco / White
- Trasparente / Transparent

Dimensioni nominali Dimensions		Contenimento indicativo di cavi Maximum elasticity of tubing
A	B	Ø mm.
1,5	3	2-12
4,2	6	5-50
6,0	8	8-70
7,6	10	12-100
9,6	12	14-120
11,6	14	18-140



Dati puramente indicativi e soggetti a modifiche.
These are indicative data and could change.

FLX

(Conformità RoHS)
(RoHS compliance)

Tipo Part number	BxHxL mm.	Cod. EAN	Imballo pz. Packing pcs.
FLX10	12,5x12,5x500	027011	50
FLX20	20x20x500	027028	50
FLX30	30x30x500	027035	50
FLX40	40x40x500	027042	50

Canale flessibile per la raccolta dei cavi.
Lunghezza: 0,5 m. con adesivo sul fondo.
IEC 216: +85°C - 110°C
temperatura esercizio continuo:
max 80°C - min -15°C
autoestinguente UL94-V2, Materiale: Nylon
Flexible duct to gather the cables.
Length: 0,5 m. with adhesive on the bottom.
IEC 216: +85°C - 110°C
continuous use temperature:
max 80°C - min -15°C
self-extinguishing UL94-V2, Material: Nylon

COLORI / COLOURS: ■ Grigio Chiaro / Light Grey

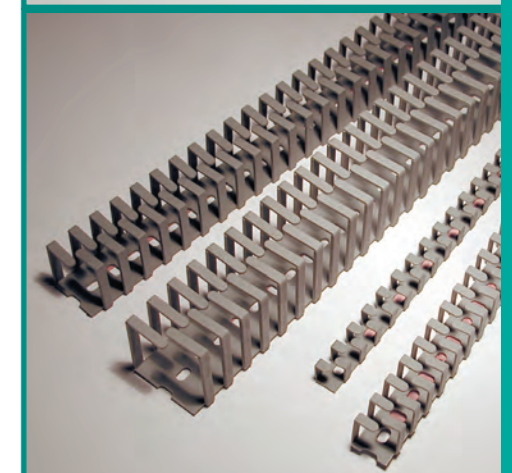
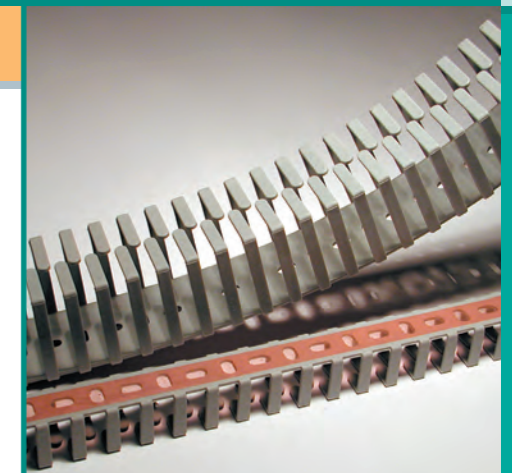
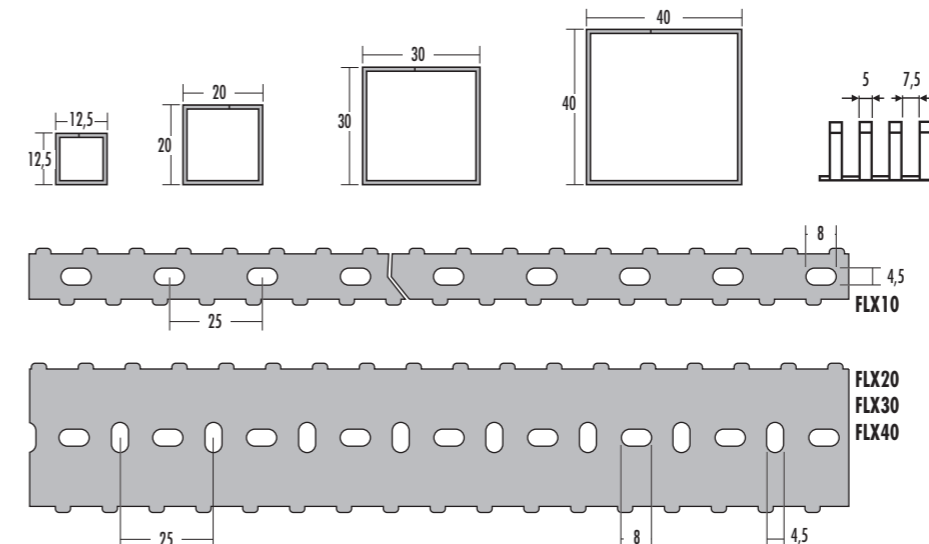

CANALI PER CABLAGGIO / WIRE DUCTS

7

GUEST

(Conformità RoHS)
(RoHS compliance)

Tipo Part number	Ø mm.	Cod. EAN	Imballo / Packing m.
GUEST 05	5	10 027400	200
GUEST 10	10	18 027417	200
GUEST 20	20	30 027424	100
GUEST 30	30	45 027431	100
GUEST 50	50	75 027448	50

COLORI/COLOURS: Grigio / Grey

NOTIZIE TECNICHE

Nessuna tossicità	Non-toxic
Resistenza alle sostanze abrasive, combustibili, liquidi, solventi, muffe	Resistant to abrasive and combustible substances, liquids, solvents, moulds
Ottima resistenza all'abrasione	Excellent resistance to abrasion
Diametro filato poliestere	Diameter of polyester yarn 0,22 mm.
Temperature di utilizzo	Working temperature -50°/+150°C
Temperatura max in uso continuo	Max continuous working temperature +120°C
Temperatura max in uso alternato	Max peak temperature +180°C
Combustibilità autoestinguente	Flammability rating UL94 HB
Indice ossigeno	Oxygen index 101.27.5
Punto di fusione	Melting point 257°C
Punto rammollimento	Softening point 230° - 240°C
Assorbimento acqua in clima normale	Water absorption in normal climate conditions 0,4%
Assorbimento acqua e saturazione	Water absorption and saturation 0,5 - 0,6%
Allungamento max alla rottura	Max elongation at break 23 - 28%
Ritiro H ₂ O a 100° CX3	Water contraction at 100° CX3 2 - 10%

SPECIFICATIONS

Guaine estensibili trecciate.
Adatta per cablaggi elettrici flessibili, la guaina estensibile agevola la protezione dall'abrasione e migliora gli isolamenti termici ed elettrici. Consente di inguainare fasci di cavi con diametri estremamente diversi, permettendo la fuoriuscita di singoli cavi attraverso le maglie divaricabili.
Materiale: Monofilamento di Poliestere
Extensible stocking sheaths.
Suitable for flexible electrical wire and cables, the extensible sheath protects the wires from abrasion and improves the thermal and electrical isolation. The GUEST sheath allows pulling wires out off the mesh at different locations.
Material: Polyester-mono-filament



GCOP

(Conformità RoHS)
(RoHS compliance)

Tipo Part number	Dimensioni / Sizes mm.
CZ GCOP15	15
CZ GCOP25	25
CZ GCOP40	40
CZ GCOP60	60
CZ GCOP80	80
CZ GCOP100	100
CZ GCOP120	120
CZ GCOP150	150
CZ GCOP200	200

Coperchi per canali Tipo E - E/4 - G.
Covers for Type E - E/4 - G trunkings.
Lunghezza / Length: 2 m

COLORI/COLOURS: G = Grigio/Grey Type 7030
 B* = Bianco/White
 BL* = Blu/Blue Type 5012
 N* = Nero/Black

*fornibile a richiesta e per quantità da concordare.
*on request and for quantities to be agreed.

Codifica per l'ordine dei coperchi
Functional part numbering system
GCOP15 ... (G o B o BL o N)
Tipo/Type Colore/Colour

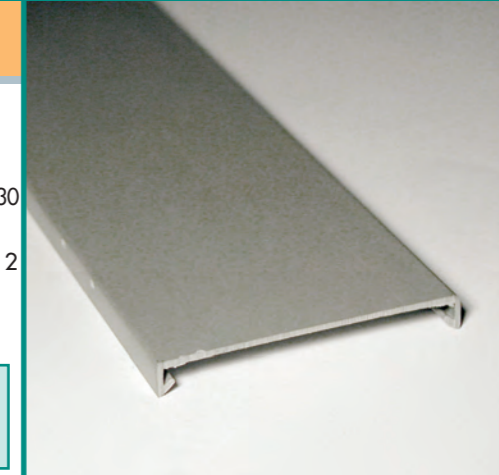

PTE

(Conformità RoHS)
(RoHS compliance)

Tipo Part number	Cod. EAN	Imballo pz. Packing pcs.
PTE	027837	250 (5x50)

COLORI/COLOURS: Trasparente / Transparent

Porta etichette canali Tipo E - E/4.
Label Holder for Type E - E/4 wire ducts.



SPIFAST

(Conformità RoHS)
(RoHS compliance)

Tipo Part number	Ø mm.	Cavi / Cables 1x2,5 max	Cod. EAN	Imballo / Packing m.
Guaina aperta / Open sheath				
SPF08N	8	6	027318	100
SPF15N	15	10	027325	50
SPF20N	20	14	027332	30
SPF25N	25	14	027349	20
Utensile per SPIFAST / Tool for SPIFAST				
SPFUT08	8	-	027356	10
SPFUT15	15	-	027363	10
SPFUT20	20	-	027370	10
SPFUT25	25	-	027387	5

COLORI/COLOURS: Nero / Black

Guaina.
Il sistema più rapido e flessibile per inguainare i cavi elettrici. Temperatura d'esercizio: -40°+85°C (-40°+185°F)
Materiale: Autoestinguente (UL94-V0).
Sheath.
The fastest system to insert wires into sheaths. Operating temperature range: -40°+85°C (-40°+185°F)
Material: Self-extinguishing (UL94-V0).

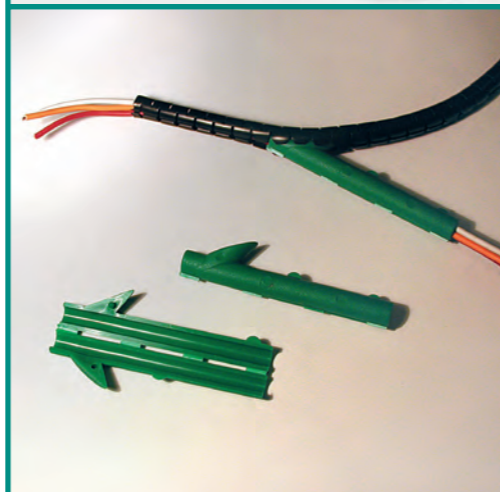

- Raccogliere i cavi nell'apposito utensile
Pick up the cables in the appropriate tool
- Introdurre il becco dell'utensile nella guaina
Insert the protruding part of the tool into the SPIFAST sheath
- Trascinare lungo la guaina l'utensile tenendo bloccato il fascio di cavi all'estremità
Keeping a firm grip on the wires/cables, drag the tool through the sheath

COVIT

(Conformità RoHS)
(RoHS compliance)

Tipo Part number	Cod. EAN	Imballo pz. Packing pcs.
COVIT	027813	1000

COLORI/COLOURS: Grigio / Grey

Copertura isolante delle viti metalliche di fissaggio.
Cover to install over if metal screws are used to secure the duct.

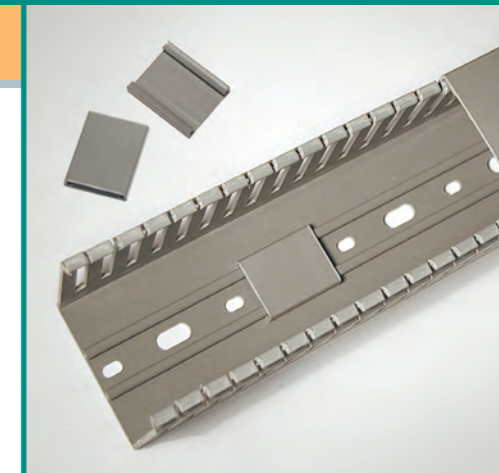
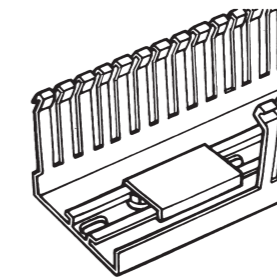

PTR

(Conformità RoHS)
(RoHS compliance)

Tipo Part number	Cod. EAN	Imballo pz. Packing pcs.
PTR	027783	100 (4x25)

COLORI/COLOURS: Giallo / Yellow

Traversino contenimento cavi per canali tipo E - E/4.
Cross arm for Type E - E/4 trunkings.

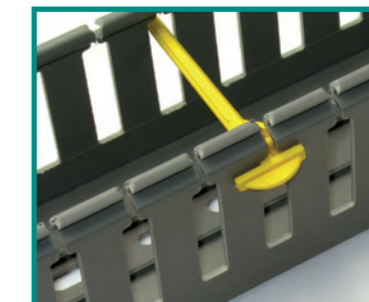

Accessori. Accessories.

TR



(Conformità RoHS)
(RoHS compliance)

Tipo Part number	Base canali Trunkings base	Cod. EAN	Imballo pz. Packing pcs.
TR4	40 mm	027738	500 (5x100)
TR6	60 mm	027745	500 (5x100)
TR8	80 mm	027752	400 (5x80)
TR10	100/120 mm	027714	250 (5x50)

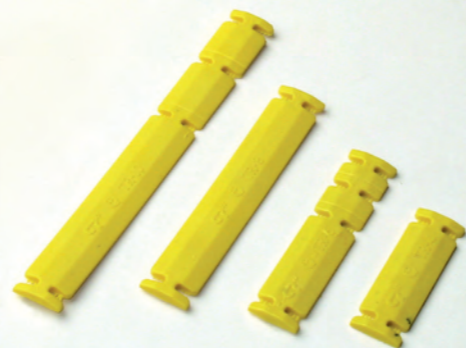

Traverse per contenere i cavi elettrici nei canali. Si inseriscono verticalmente nelle fessure. Si incastrano con movimento rotatorio sulle alette, impedendo la fuoriuscita dei cavi. Install between the duct fingers to retain the cables when the cover is removed. Adjustable along finger length to retain large or small wire bundles.

COLORI/COLOURS: Giallo / Yellow

FCV

(Conformità RoHS)
(RoHS compliance)

Tipo Part number	Per canali For trunkings	Cod. EAN	Imballo pz. Packing pcs.
FCV12040	60/120x40	033333	40
FCV12060	40/200x60	033340	25



Traversino contenimento cavi.

Si monta a scatto negli appositi ganci sulla base interna del canale. Fratturare le alette in funzione della larghezza del canale.

Cable-retaining Cross-arm.

It can be snapped on into the proper hooks located in the inner base of the duct. Break the fins according to the width of the duct.

COLORI/COLOURS: Giallo / Yellow

S



(Conformità RoHS)
(RoHS compliance)

Tipo Part number	H mm	Cod. EAN	Imballo m Packing m
S1 (2 separatori)	40	032916	30
S2	60	032923	50
S3	40	032930	60
S4	80	032947	32
S5	100	032954	32

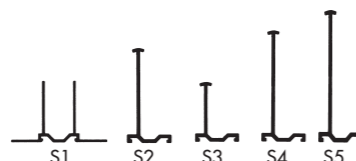

Separatore cavi.

Per separare i cavi all'interno dei canali. Si monta a scatto sulle guide presenti sul fondo del canale.

Opportunamente posizionato crea scomparti di sezione diversa.

Cable separator.

For separating the cables housed inside the ducting. Snap on the built-in rail of the duct. Several separation schemes can be obtained using different separators.

COLORI/COLOURS: Grigio / Grey

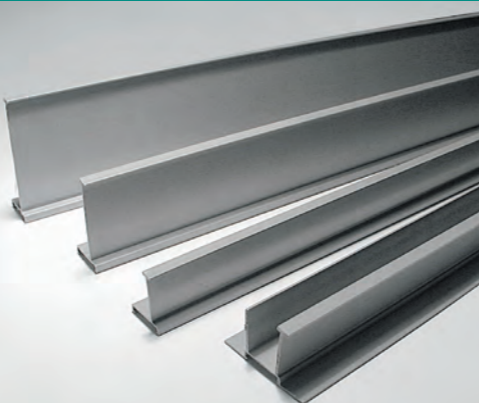

DMF



(Conformità RoHS)
(RoHS compliance)

Tipo Part number	Cod. EAN	Imballo pz. Packing pcs.
DMF	050620	100 (2x50)

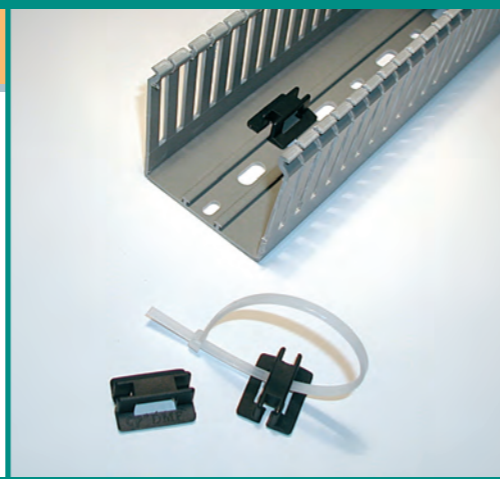

Porta fascette.

Si monta a scatto negli appositi ganci sul fondo interno del canale.

Materiale: Nylon

Cable tie holder which can be attached to all ducts fitted with a base rail.

Material: Nylon

COLORI/COLOURS: Nero / Black

Accessori. Accessories.

MARK15KIT

(Conformità RoHS)
(RoHS compliance)

Tipo Part number	Cod. EAN	Imballo kit Packing kit
MARK15KIT	027059	20

Kit per l'identificazione del contenuto dei canali (E-E4).

Il Kit comprende:

- n. 10 coperchi portaetichette. Lunghezza barra 0,5 m.

- n. 20 portacoperchio

Wire duct identification Kit (E-E4). Kit content:

- n. 10 label-holder cover. Bar length 0,5 m.

- n. 20 cover-holders

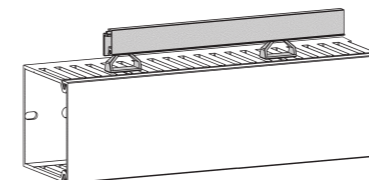
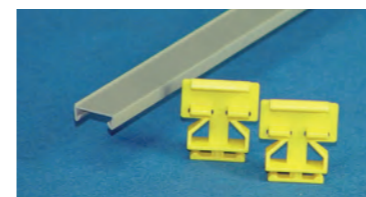

COLORI/COLOURS: Grigio / Grey (Coperchio / Cover)
 Giallo / Yellow (Portacoperchio / Cover-holder)

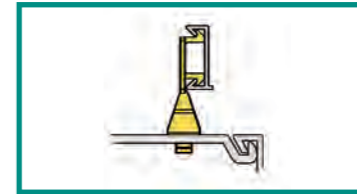
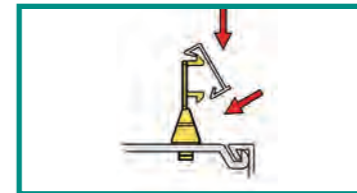
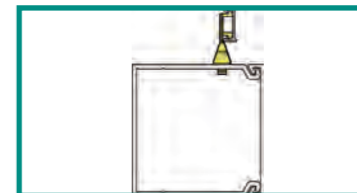

PTECO15

(Conformità RoHS)
(RoHS compliance)

Tipo Part number	Cod. EAN	Imballo m. Packing m.
PTECO15	027073	150

Coperchi portaetichette 15 mm. Lunghezza barra: 1m.

Usare con PTECO.

Label-holder cover 15mm. - Bar length 1m.

Use with PTECO

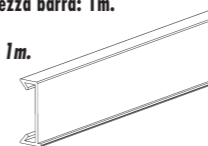

COLORI/COLOURS: Grigio / Grey

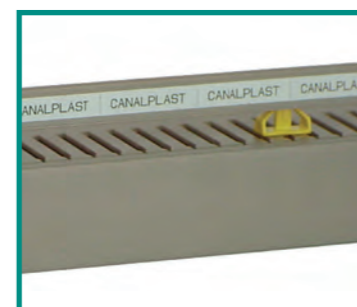

PTECO

(Conformità RoHS)
(RoHS compliance)

Tipo Part number	Cod. EAN	Imballo pz. Packing pcs.
PTECO	027066	150

Portacoperchio per PTECO15.

Cover holder for PTECO15.

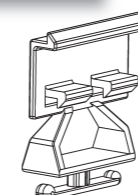

COLORI/COLOURS: Giallo / Yellow

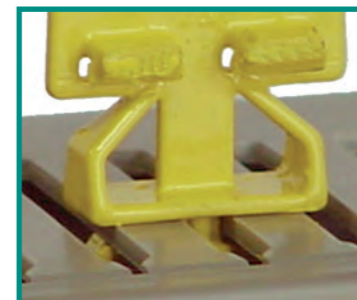

Accessori e utensili. Accessories and tools.

FMC



(Conformità RoHS)
(RoHS compliance)

Tipo Part number	Cod. EAN	Imballo pz. Packing pcs.
FMC	015100	40 (4x10)

Fermacavo universale per canali H.60/80 mm.
Applicato sulle guide dei canali impedisce lo spostamento accidentale dei cavi. Può contenere 3 cavi (massimo 5mm di diametro) per ogni foro (2).
Universal cable-holder. For wire ducts H. 60/80 mm.
Application on the built-in rail of the duct to avoid accidental pulling of the wires. It can contain 3 wires (of maximum 5mm of diameter) for each hole (2).

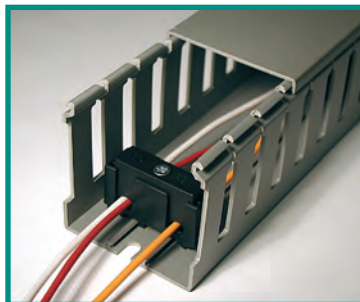

COLORI/COLOURS: ■ Nero / Black



ETC120 / ETC120L

Tipo Part number	Cod. EAN	Imballo pz. Packing pcs.
ETC120	028001	1
ETC120L	027936	1

Taglierina per canali tipo E - E/4.
max 120x120 mm
ETC120L: Lama di ricambio per ETC120.

Cutter for Type E - E/4 trunkings.
max 120x120 mm (4.75 x 4.75 in.)
ETC120L: Spare blade for ETC120.

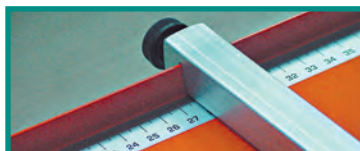

Questa taglierina manuale da banco vi permetterà tagli precisi dei canali grazie alla barra metrica dotata di fermo posta sul lato della taglierina.
This bench-mounted cutter will allow you to cut precise lengths of ducts, thank to the attached ruler stuck on the side panel. The well-sharpened blade will give you burr-free results as well.

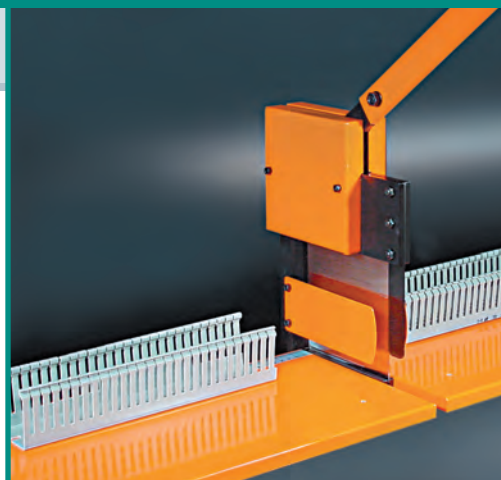

RIV1 / RIV2



(Conformità RoHS)
(RoHS compliance)

Tipo Part number	Ø mm	Cod. EAN	Imballo pz. Packing pcs.
RIV1	6,5	027615	1000 (5x200)
RIV2	4,5	027622	1000 (5x200)

Rivetti. Per il fissaggio dei canali sui pannelli. Con perno attaccato. Materiale: Nylon
Rivets. To fix the ducts to panels. Material: Nylon

COLORI: RIV1 ■ Nero / Black
COLOURS: RIV2 ■ Verde / Green

RIV1 espansione da 6,5 a 7,5 mm
RIV2 da 4,5 a 5,5 mm
RIV1 expansion from 6,5 to 7,5 mm
RIV2 from 4,5 to 5,5 mm

Tipo Type	A	B	C	D
RIV1	11,3	6	2	10
RIV2	10	4,5	3	8,5

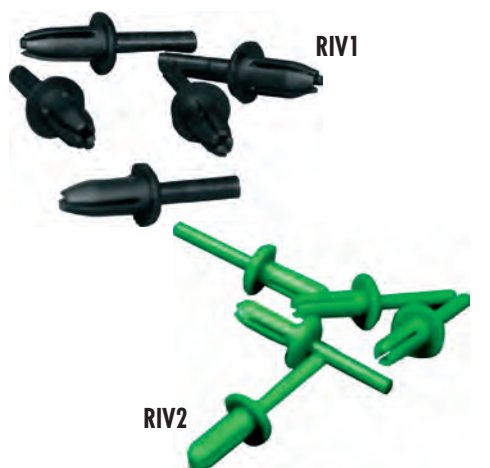
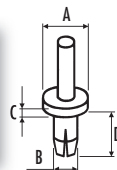

PRRIV

Tipo Part number	Ø mm	Cod. EAN	Imballo pz. Packing pcs.
PRRIV	6,5	027981	4 (4x1)
PRRIV2	4,5	027998	4 (4x1)

Premirivetto. Utensile per l'applicazione rapida dei rivetti RIV1 e RIV2.
Riveting tool. For the fast installation of the RIV1 and RIV2 rivets.

PRRIV = Premirivetto per RIV1 / Riveting tool RIV1
PRRIV2 = Premirivetto per RIV2 / Riveting tool RIV2

COLORI: PRRIV ■ Nero / Black
COLOURS: PRRIV2 ■ Verde / Green



8 Guide metalliche. DIN rails.

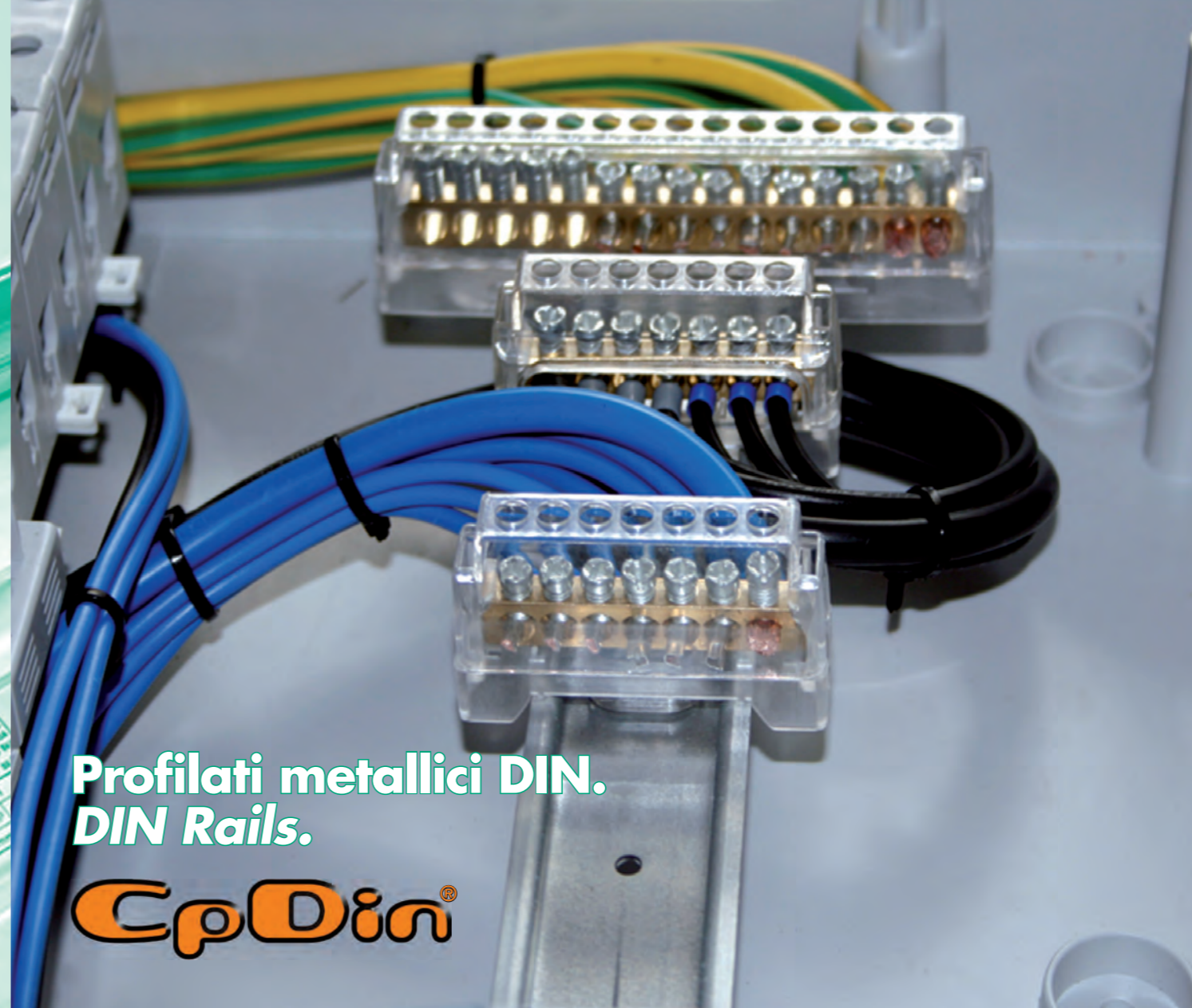

**Profilati metallici DIN.
DIN Rails.**

CPDIN®



**Profilati metallici DIN.
DIN Rails.**
pag. 8.1.1



CPDIN
pag. 8.2.1

Profilati metallici DIN. Guide a norme
UNI 5961-67, Zincatura in Sendzimir.
DIN Rails. Rails to UNI 5961-67 standards,
Sendzimir zinc plating.



pagina / page 8.1.2

CPDIN.
Morsettiere di distribuzione.
CPDIN.
Protected terminal posts.



pagina / page 8.2.1

Profilati metallici DIN. DIN Rails.

Guide a norme UNI 5961-67, Zincatura in Sendzimir.
Spessore rivestimento = 8 micron
Corrispondenza a: Norme DIN 46277,
CENELEC EN50.022 / EN 50.023 / EN50.035.
In conformità alle direttive Weee e RoHS.

Rails to UNI 5961-67 standards, Sendzimir zinc plating.
Thickness of covering = 8 microns
Compliance with the following standards: DIN 46277,
CENELEC EN50.022 / EN 50.023 / EN50.035.
In according to Weee and RoHS directives.

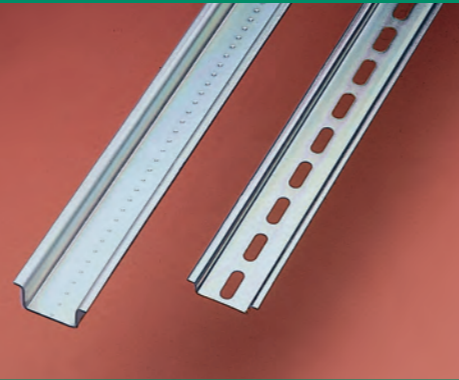

Profilati metallici DIN. DIN Rails.

PD32Z

(Conformità RoHS)
(RoHS compliance)

Tipo Part number	Cod. EAN	Imballo m. Packing m.
PD32Z	101049	20

COLORE:
COLOUR: Sendzimir

Guida di supporto in acciaio per il fissaggio a scatto di morsetti o per il montaggio di apparecchiature ed intelaiature mediante l'apposito attacco PDC 46. Esecuzione secondo: norme DIN 46277/Foglio 1, norme CENELEC EN 50.035. Lunghezza: Barre da 2 m

Steel support rail to snap-on clamps for assembling equipment and frames using the special coupling PDC 46. Manufactured according to the following standards: DIN 46277/Page 1, CENELEC EN 50.035. Length: 2m bars

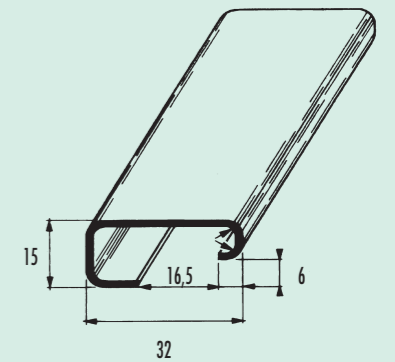

PD35CZ

(Conformità RoHS)
(RoHS compliance)

Tipo Part number	Cod. EAN	Imballo m. Packing m.
PD35CZ	101001	20

COLORE:
COLOUR: Sendzimir

Guida di supporto in acciaio per il montaggio a scatto di apparecchiature elettriche. Esecuzione secondo norme CENELEC EN 50.022.
Lunghezza: Barre da 2 m

Steel support rail to snap-on electrical equipment. Manufactured according to the CENELEC EN 50.022 standards. Length: 2m bars

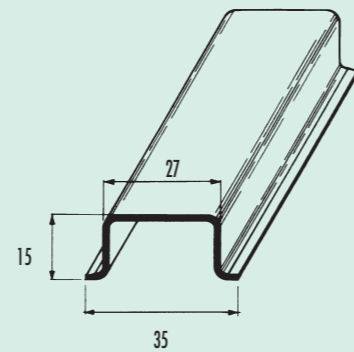

PD32ZF6

(Conformità RoHS)
(RoHS compliance)

Tipo Part number	Cod. EAN	Imballo m. Packing m.
PD32ZF6	101056	20

COLORE:
COLOUR: Sendzimir

Guida di supporto forata in acciaio. Esecuzione secondo: norme DIN 46277/Foglio 1, norme CENELEC EN 50.035. Lunghezza: Barre da 2 m

Perforated steel support rail. Manufactured according to the following standards: DIN 46277/Page 1, CENELEC EN 50.035. Length: 2m bars

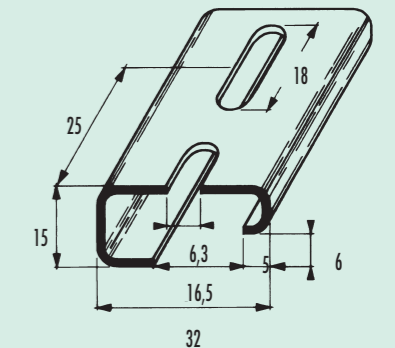

PD35Z

(Conformità RoHS)
(RoHS compliance)

Tipo Part number	Cod. EAN	Imballo m. Packing m.
PD35Z	101025	40

COLORE:
COLOUR: Sendzimir

Guida di supporto in acciaio per il montaggio a scatto di apparecchiature elettriche. Esecuzione secondo: norme DIN 46277/Foglio 3, norme CENELEC EN 50.022. Lunghezza: Barre da 2 m

Steel support rail to snap-on electrical equipment. Manufactured according to the following standards: DIN 46277/Page 3 CENELEC EN 50.022 Length: 2m bars

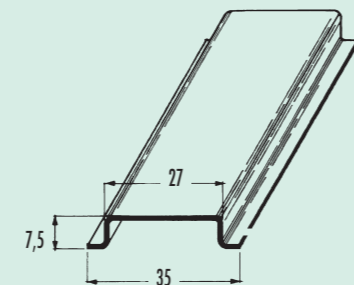

PDC46

(Conformità RoHS)
(RoHS compliance)

Tipo Part number	Cod. EAN	Imballo pz. Packing pcs.
PDC46	100073	100

COLORE:
COLOUR: Bianco / White

Attacco universale per guida tipo PD32. In nylon stampato con piastrina zincata e passivata gialla con due fori filettati M4-M6. Per il fissaggio di apparecchiature su guida PD32 anche sprovviste di piede adatto. Esecuzione secondo: norme DIN 46277/Foglio 1, norme CENELEC EN 50.035.

All-purpose coupling for PD32 rail. In moulded nylon with yellow passivated and galvanised plate with two M4-M6 threaded holes. For coupling of equipment on a PD32 rail even without suitable foot. Manufactured according to the following standards: DIN 46277/Page 1, CENELEC EN 50.035.

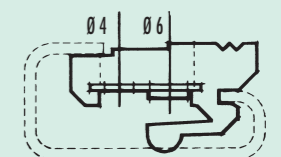

PD35CZF6

(Conformità RoHS)
(RoHS compliance)

Tipo Part number	Cod. EAN	Imballo m. Packing m.
PD35CZF6	101018	20

COLORE:
COLOUR: Sendzimir

Guida di supporto forata in acciaio. Esecuzione secondo norme CENELEC EN 50.022. Lunghezza: Barre da 2 m

Perforated steel support rail. Manufactured according to the CENELEC EN 50.022 standards. Length: 2m bars

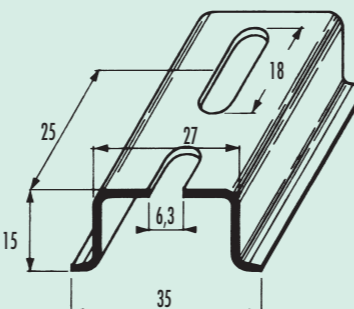

PDC35

(Conformità RoHS)
(RoHS compliance)

Tipo Part number	Cod. EAN	Imballo pz. Packing pcs.
PDC35	100097	100

COLORE:
COLOUR: Nero / Black

Attacco universale per guida tipo PD32. In nylon stampato con piastrina zincata e passivata gialla con due fori filettati M3-M5. Per il fissaggio di apparecchiature su guida PD32 anche sprovviste di piede adatto. Esecuzione secondo: norme DIN 46277/Foglio 1, norme CENELEC EN 50.035.

All-purpose coupling for PD32 rail. In moulded nylon with yellow passivated and galvanised plate with two M3-M5 threaded holes. For coupling of equipment on a PD32 rail even without suitable foot. Manufactured according to the following standards: DIN 46277/Page 1, CENELEC EN 50.035.

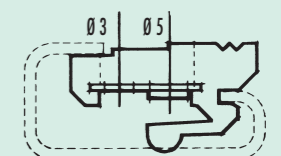

PD35ZF6

(Conformità RoHS)
(RoHS compliance)

Tipo Part number	Cod. EAN	Imballo m. Packing m.
PD35ZF6	101032	40

COLORE:
COLOUR: Sendzimir

Guida di supporto forata in acciaio. Esecuzione secondo: norme DIN 46277/Foglio 3, norme CENELEC EN 50.022. Lunghezza: Barre da 2 m

Perforated steel support rail. Manufactured according to the following standards: DIN 46277/Page 3, CENELEC EN 50.022. Length: 2m bars

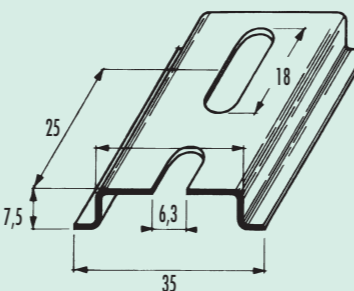

PDSZM6

(Conformità RoHS)
(RoHS compliance)

Tipo Part number	Cod. EAN	Imballo pz. Packing pcs.
PDSZM6	101063	10

COLORE:
COLOUR: Sendzimir

Staffa di supporto in acciaio zincato con foro filettato M6.

Support bracket in galvanised steel with M6 threaded hole.

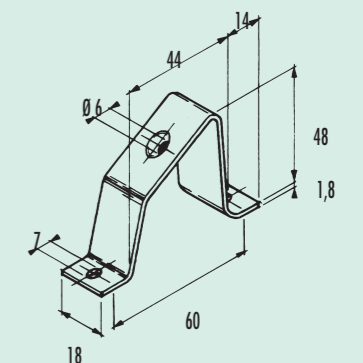

Morsettiere di distribuzione. Morsettiere bipolari e tetrapolari.
Protected terminal posts. Bipolar and tetrapolar protected terminal posts.

Caratteristiche Generali

- Tensione di isolamento 500V
- Fissaggio profilato EN 50022 o a pannello
- Schermo isolante per ogni barretta di ottone
- Fori di alimentazione appositamente resi sfalsati per un miglior cablaggio dei conduttori
- Grado di protezione IP00
- IMQ

General characteristics

- Insulating tension 500V
- Fixing on profiled frame EN 50022 or panel
- Insulating screen for each brass bar
- On-purpose offset realization of the feed-in-holes to permit an easier wiring of the conductors
- Protection degree IP00
- IMQ

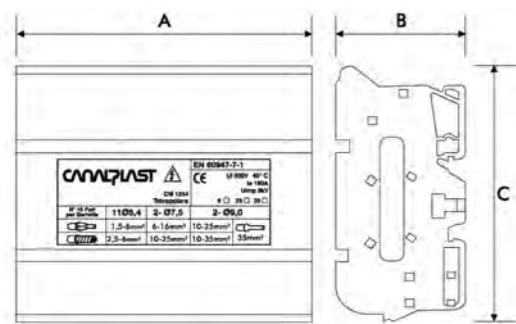
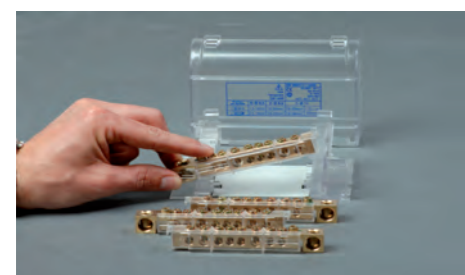
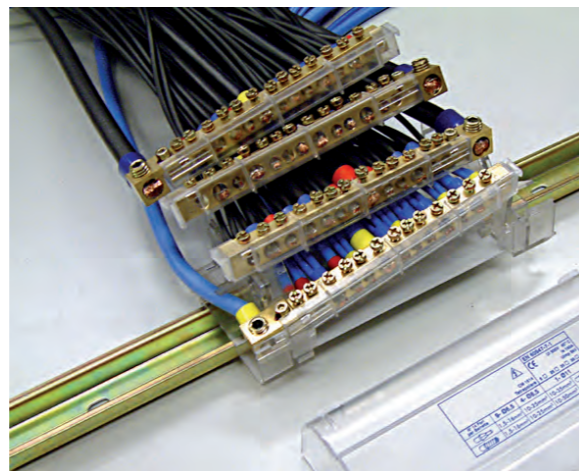

Materiali Utilizzati

- Ottone CW 614 N
- Viti in ferro zincato con taglio combinato
- Policarbonato autoestinguente secondo UL 94

Materials

- Brass CW 614 N
- Zinc plated iron screws with combined cut
- Self-extinguishing polycarbonate according to UL 94

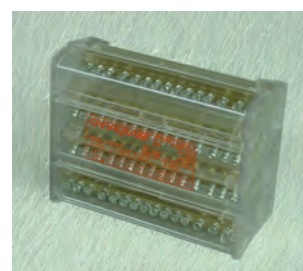

Informazioni di installazione

- Assicurarsi che la morsettiere sia perfettamente agganciata sul supporto guida DIN
- Per utilizzare tutti i fori disponibili sulle barrette si consiglia di adoperare per i cavi di sezione maggiore i puntalini senza isolatore.

Assembling instruction

- Make sure that the terminals are all perfectly engaged on the slide support DIN
- To use all the available holes on the bars it is suggested to get the cables of wider sections equipped with rods without insulator.

Principali impieghi

- Le morsettiere di distribuzione servono a raggruppare tutti i cavi secondari ad un'unica linea principale; soprattutto nei quadri elettrici o di distribuzione.

Main uses

- Protected terminal posts are used to join the secondary cables with a single main line, especially into the electrical or distribution panels.

Morsettiere di distribuzione. Morsettiere bipolari e tetrapolari.
Protected terminal posts. Bipolar and tetrapolar protected terminal posts.

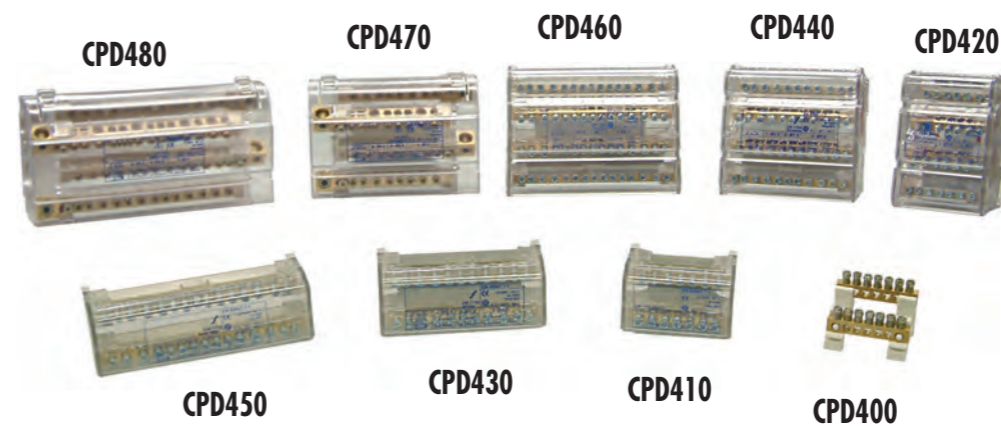

N.B. L'intera gamma è stata progettata in modo da poter sganciare e rimuovere le barre di ottone.

N.B.: the whole range has been designed to allow to disengage and remove the brass bars.

Tipo	Descrizione	EAN	N° fori per barretta	Sez. conduttore con puntale	Sez. conduttore senza puntale	Dimensioni			N° moduli	Portata A	IpK kA	Icw kA	Imballo pz.
						A	B	C					
Part number	Description	EAN Code	N. holes per bar	Sec. of conductor with rod	Sec. of conductor without rod	Dimensions			N. of modules	Capacity A			Packing pcs.
CPD400*	Morsettiere bipolare 5 fori da 63A Bipolar terminal 5 holes of 63A	161425	5 fori da 6,50	da 1,5 a 16	da 2,5 a 16	47	50	42	4	63	-	-	10
CPD410	Morsettiere bipolare 7 fori da 100A Bipolar terminal 7 holes of 100A	161432	5 fori da 5,40 2 fori da 7,50	da 1,5 a 6 da 6 a 16	da 2,5 a 6 da 10 a 25	70	50	50	4	100	22	3	4
CPD420	Morsettiere tetrapolare 7 fori da 100A Tetrapolar terminal 7 holes of 100A	161449	5 fori da 5,40 2 fori da 7,50	da 1,5 a 6 da 6 a 16	da 2,5 a 6 da 10 a 25	70	50	90	4	100	22	3	2
CPD430	Morsettiere bipolare 11 fori da 125A Bipolar terminal 11 holes of 125A	161456	7 fori da 5,40 2 fori da 7,50 2 fori da 9,00	da 1,5 a 6 da 6 a 16 da 10 a 25	da 2,5 a 6 da 10 a 25 da 10 a 35	110	50	50	6	125	19	4,2	2
CPD440	Morsettiere tetrapolare 11 fori da 125A Tetrapolar terminal 11 holes of 125A	161463	7 fori da 5,40 2 fori da 7,50 2 fori da 9,00	da 1,5 a 6 da 6 a 16 da 10 a 25	da 2,5 a 6 da 10 a 25 da 10 a 35	110	50	90	6	125	19	4,2	1
CPD450	Morsettiere bipolare 15 fori da 125A Bipolar terminal 15 holes of 125A	161470	11 fori da 5,40 2 fori da 7,50 2 fori da 9,00	da 1,5 a 6 da 6 a 16 da 10 a 25	da 2,5 a 6 da 10 a 25 da 10 a 35	141	50	50	8	125	19	4,2	2
CPD460	Morsettiere tetrapolare 15 fori da 125A Tetrapolar terminal 15 holes of 125A	161487	11 fori da 5,40 2 fori da 7,50 2 fori da 9,00	da 1,5 a 6 da 6 a 16 da 10 a 25	da 2,5 a 6 da 10 a 25 da 10 a 35	141	50	90	8	125	19	4,2	1
CPD470	Morsettiere tetrapolare 9 fori da 160A Tetrapolar terminal 9 holes of 160A	161494	6 fori da 6,50 2 fori da 8,50 1 foro da 11,00	da 1,5 a 6 da 10 a 25 da 10 a 35	da 2,5 a 16 da 10 a 35 da 10 a 50	136	52	94	8	160	28	6	1
CPD480	Morsettiere tetrapolare 14 fori da 160A Tetrapolar terminal 14 holes of 160A	161500	9 fori da 6,50 4 fori da 8,50 1 foro da 11,00	da 1,5 a 6 da 10 a 25 da 10 a 35	da 2,5 a 16 da 10 a 35 da 10 a 50	186	52	94	10	160	28	6	1

* No IMQ

Morsettiere di distribuzione. Morsettiere di ripartizione universali.
Protected terminal posts. Protected terminal universal posts.



Caratteristiche Generali

- Morsettiere di ripartizione protette a 7, 11 e 15 fori
- Fissaggio su guida DIN o con vite su parete
- Tensione di isolamento 500V
- Resistenza al calore: 130 °C
- Portata nominale: 57 A
- IMQ

General characteristics

- Protected terminal posts with 7, 11 and 15 holes
- Fastening on slide DIN or with screw to the wall
- Voltage: 500 V
- Heat resistance: 130 °C
- Max nominal current: 57 A
- IMQ

Conforme alle norme

- EN 60998-1:1993 + A1/2001
- EN 60998-2:1993
- Grado di protezione: IP00
- Conforme direttive 2002/95/CE (RHOS)

Compliant to Standards

- EN 60998-1:1993 + A1/2001
- EN 60998-2:1993
- Protection degree: IP 00
- Compliant directive 2002/95/CE (RHOS)

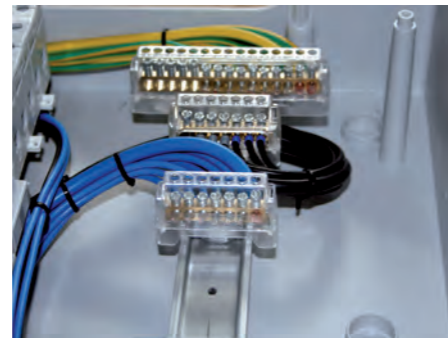
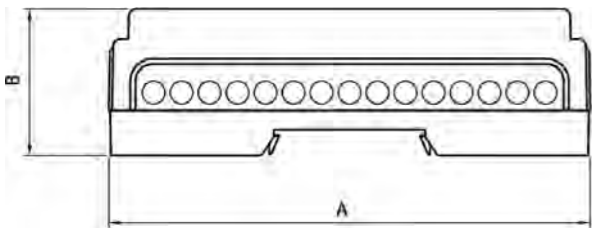

Principali impieghi

- Le morsettiere di ripartizione vengono utilizzate come morsettiere supplementari per espansione di fase o neutro all'interno di quadri elettrici.
- Sono dette anche morsettiere equipotenziali poiché sono utilizzate come nodo equipotenziale nei centralini di distribuzione per raccogliere l'impianto di terra.

Main uses

- The protected terminal posts are used as additional terminal posts for phase or neutral expansion inside electric panels.
- They are also known as equi-joints since they are used as equipotential nodes in control units to contain the earthing.

Materiali Utilizzati

- Ottone CW 614 N
- Viti in ferro zincato con taglio combinato
- Policarbonato trasparente

Materials

- Brass CW 614 N
- Zinc plated iron screws with combined cut
- Transparent polycarbonate



Tipo	Descrizione	EAN	Barretta Bar		Sezione Cavi Cable section		Dimensioni Dimensions			Imballo pz. Packing pcs.
			N° fori N. holes	Diametro Diameter	Flessibili Flexibil	Flessibili con puntale Flexibil with terminal	A	B	C	
CPD500	Morsettiere Unipolare Unipolar terminal block	161630	7	5,3	1,5 - 10	1,5 - 10	60	34	20	10
CPD510	Morsettiere Unipolare Unipolar terminal block	161647	11	5,3	1,5 - 10	1,5 - 10	87	34	20	10
CPD520	Morsettiere Unipolare Unipolar terminal block	161654	15	5,3	1,5 - 10	1,5 - 10	113	34	20	10

Morsettiere di distribuzione. Supporti barre di rame.
Protected terminal posts. Copper bars support.

Caratteristiche Generali

- Fissaggio su guida DIN o su fondo
- Progettato per l'utilizzo delle barre standard
- I supporti sono forniti in kit senza barre rame, per dare la possibilità di variare a piacimento la dimensione della larghezza dello stesso, quindi attenersi alle note per l'assemblaggio
- Predisposizione all'aggancio della copertura superiore (opzionale).

Note per l'assemblaggio

- Utilizzare le barre riportate in tabella
- Predisporre le alimentazioni delle barre all'esterno delle stesse allargando il foro di alimentazione in base alla dimensione della barra ed alla corrente di esercizio. (in genere diam. 8 per 15x5 e diam. 10 per 30x5)
- La lunghezza delle barre rame dipende dalla corrente di cortocircuito. Attenersi alla tabella.
- Viterie di fissaggio in dotazione

General characteristics

- Fixing on DIN rails or on bottom
- Planned to be used on standard bars
- The supports are supplied in kit without copper bars to give the possibility to vary the dimension of the bar and the operating current follow the assembling instructions.
- Pre-set for the hooking of the upper cover (optional).

Assembling instructions

- Use only the bars reported in the table
- Prepare the feeding of the bars on their ends enlarging the feeding hole according to the dimension of the bar and the operating current (in general Ø 8 per 15x5 and Ø 10 per 30x5)
- The length of the copper bars depends on the short circuit current. Follow the table.
- Fixing screws enclosed

CPD610

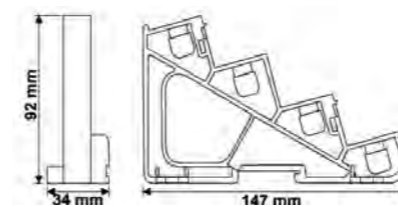

CPD600

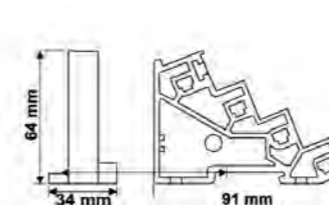

Tipo	Descrizione	EAN	Portata A	Dimensione barre	Icc eff./1s					Imballo pz.
					5kA	10kA	15kA	20kA	25kA	
CPD600	Supporto tetrapolare Tetrapolar support	161517	125	12x4	500					1 coppia
					160	15x5	500	325		
CPD610	Supporto tetrapolare Tetrapolar support	161524	250	20x5	750	325				1 coppia
					400	30x5	750	325	200	175

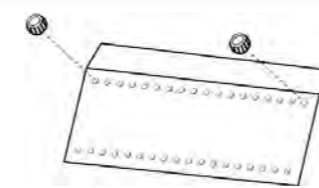

Tipo	Descrizione	EAN	Dimensioni	Imballo pz.
CPD600C	Copertura per CPD600 Cover for CPD600	161531	Fori a passo 25 x Lung. 1 mt. Holes with thread 25 per 1 mt. of length	1
CPD610C	Copertura per CPD610 Cover for CPD610	161548	Fori a passo 25 x Lung. 1 mt. Holes with thread 25 per 1 mt. of length	1



Morsettiere di distribuzione. Supporti barre di rame.
Protected terminal posts. Copper bars support.

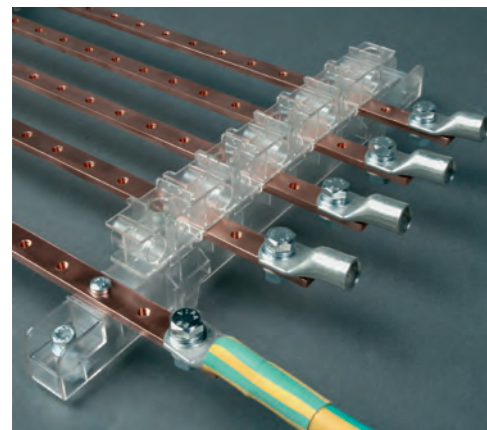

Caratteristiche generali

- Supporto isolante per sistemi di sbarre posteriori
- Predisposizione per aggiungere la 5a barra di terra con sez. 15x5 o 20x5
- Rotazione del supporto superiore in 4 posizioni per adattarsi alla dimensione della barra utilizzata
- Materiali autoestinguenti secondo UL94
- Montaggio su guida DIN o pannello

General characteristics

- Insulating support for back bar systems
- Pre-set for adding the 5th earthing bar with sec. 15x5 or 20x5
- Rotation of the upper support on 4 positions to fit the dimension of the employed bar
- Fire retardant materials according to UL94

Particolarità di montaggio

- Ruotando opportunamente il supporto superiore è possibile fissare una serie dei quattro tipi di barre indicate in tabella.

Assembly characteristics

- By turning appropriately the upper support it is possible to fix a series of the four types of bars indicated in the table.

- Viteria di fissaggio in dotazione
- Fixing screws enclosed

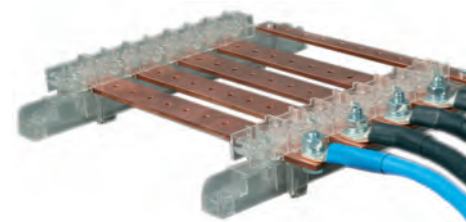

Tipo	Descrizione	EAN	Portata A	Dimensione barre	Icc eff./1s					Imballo pz.
Part number	Description	EAN Code	Capacity A	Bar dimension	5kA	10kA	15kA	20kA	25kA	Packing pcs.
CPD650	Supporto per barre rame Bar system support	161555	160	15x5	500	450				1 coppia
			250	20x5	750	450				1 couple
			320	25x5	750	450		300		
			400	32x5	750	450		300	75	
					Dimensione tra gli interassi dei supporti in mm. Dimension between the interaxis of the supports in mm.					

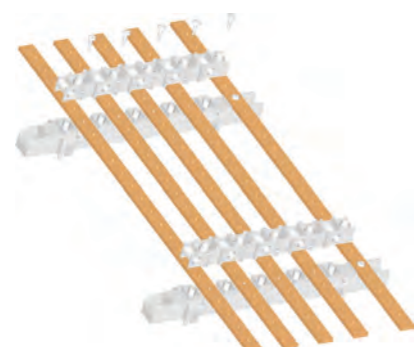
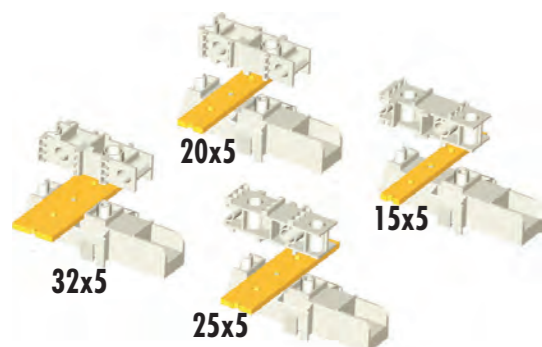
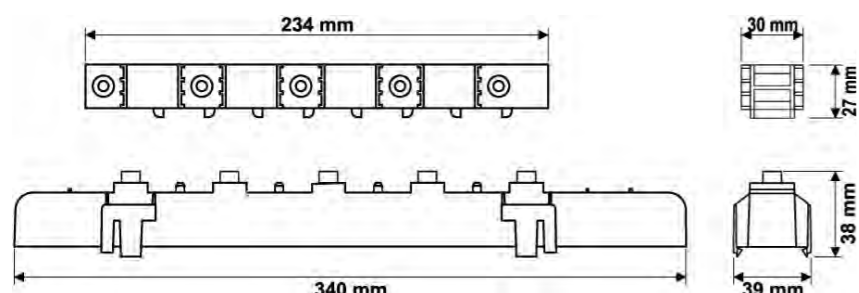

Morsettiere di distribuzione. Morsettiere a doppio serraggio ed equipotenziali.
Protected terminal posts. Double screw tightening and equipoint terminals.

Doppio Serraggio. Double screw tightening.

Caratteristiche Generali

- Resistenza al calore 125 °C
- Attacco guida DIN
- Rotazione del supporto con fissaggio sia verticale che orizzontale
- Portata nominale 80 A

Materiali utilizzati

- Ottone CW 614 N
- Doppia vite per ogni cavo in ferro zincato a taglio combinato

Principali impieghi

- Le morsettiere di derivazione a doppio serraggio si utilizzano nelle cassette o su guida DIN, quando bisogna derivare una linea principale, aggiungendo al massimo altre due linee per polo secondarie.
- Il doppio serraggio a normative VDE garantisce la sicurezza del collegamento stesso.

General characteristics

- Heat resistance 125 °C
- Slide joint DIN
- Support rotation with either vertical or horizontal fixing
- Max nominal current 80 A

Materials

- Brass CW 614 N
- Double screw for each zinc plated iron cable of combined cut

Main uses

- Double screw tightening terminals are used in junction boxes or in DIN rail, when a main existing line needs to be derived, adding maximum two other secondary lines per pole.
- The double screw according to VDE standards guarantees the safety of the connection.



Tipo	EAN	N° poli	Passante sez.	Derivanti sez. Max	Dimensioni Dimensions			Imballo pz.	Peso g
Part number	EAN Code	N. of poles	By-passing sec.	Deriving sec. Max	A	B	C	Packing pcs.	Weight g
CPD700	161562	1	25	2x16	22	43	35	5	67
CPD710	161579	2	25	2x16	42	43	35	2	124
CPD720	161586	3	25	2x16	62	43	35	1	179
CPD730	161593	4	25	2x16	82	43	35	1	242

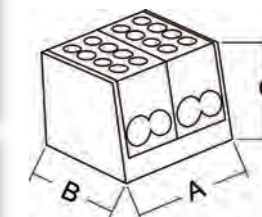

Equipotenziali. Equipoints.

Caratteristiche Generali

- Serraggio con doppia vite
- Coperchio facilmente asportabile
- Piastrina per il collegamento di più morsettiere tramite barra o tondino di rame
- Utilizzate per raccogliere l'impianto di terra in un unico nodo principale

Materiali utilizzati

- Ottone o barre rame
- Viti o bulloni zincati a taglio combinato

Conforme alle norme

- DIN VDE 0618-1

General characteristics

- Double screw tightening
- Easy removal of cover
- Plate to connect with more than one terminal through bars or copper rods
- Used to get together the earthing in only one main knot

Materials

- Brass or copper bars
- Zinc plated screws or bolts with simple or combined cut

Complying with norms

- DIN VDE 0618-1

Tipo	Caratteristiche aggiuntive	EAN	Ø Foro cavo principale	Sezione minima	Sezione massima	Dimensioni Dimensions			Collegamento con barra rame o zincata	Imballo pz.	Peso g
Part number	Additional characteristics	EAN Code	Ø main cable hole	Minimal section	Max section	A	B	C	Copper or zincated bar connection	Packing pcs.	Weight g
CPD800	Coperchio di protezione Protecting cover	161609	1x25	5x1,5	5x6	65	41	33	-	10	66
CPD810	Coperchio di protezione Protecting cover	161616	1x50	7x6	7x25	174	40	52	30x4 mm o tondino da Ø8-10 mm.	10	228
CPD820	Coperchio a cerniera Zip-like cover	161623	1x50	6x6 1x2,5	6x25 1x6	182	38	44	30x4 mm o tondino da Ø8-10 mm.	10	162

